

Getting Started with

TI-*nspire*™

Math & Science Learning Technology



Important notice regarding book materials

Texas Instruments makes no warranty, either expressed or implied, including but not limited to any implied warranties of merchantability and fitness for a particular purpose, regarding any programs or book materials and makes such materials available solely on an “as is” basis. In no event shall Texas Instruments be liable to anyone for special, collateral, incidental, or consequential damages in connection with or arising out of the purchase or use of these materials, and the sole exclusive liability of Texas Instruments, regardless of the form of action, shall not exceed the purchase price of the book. Moreover, Texas Instruments shall not be liable for any claim of any kind whatsoever against the use of these materials by any other party.

Permission is hereby granted to teachers to reprint or photocopy in classroom, workshop, or seminar quantities the page or sheets in this work that carry a Texas Instruments copyright notice. These pages are designed to be reproduced by teachers for use in their classes, workshops, or seminars, provided that each copy made shows the copyright notice. Such copies may not be sold, and further distribution is expressly prohibited. Except as authorized above, prior written permission must be obtained from Texas Instruments Incorporated to reproduce or transmit this work or portions thereof in any form or by any electronic or mechanical means, including any information storage or retrieval system, unless expressly permitted by federal copyright law. Send inquiries to this address:

Texas Instruments Incorporated
7800 Banner Drive, MS 3918
Dallas, Texas 75251
Attention: Manager, Business Services

Copyright © 2007 Texas Instruments Incorporated. Except for the specific rights granted herein, all rights are reserved.
Printed in the United States of America.
CBR 2™, TI-Nspire™, TI-89 Titanium™, and TI Connect™ are trademarks of Texas Instruments Incorporated.
All other trademarks are the property of their respective owners.

We invite your comments and suggestions about this book. Call us at 1-800-TI-CARES or send e-mail to ti-cares@ti.com. You can also call or send an e-mail to request information about other current and future publications from Texas Instruments.

Visit the TI World Wide Web home page. The web address is: education.ti.com

About this booklet

This booklet offers step-by-step introductory tutorials and activities which take the user through many key features of TI-Nspire™ math and science learning technology. TI-Nspire learning technology includes handhelds and computer software, providing educators the flexibility to meet different classroom needs. The primary focus of the material in this guide is the handheld device, but all activities are equally applicable to the computer software.

What is TI-Nspire™?

- Multiple representations, dynamically linked, encouraging multiple approaches to solving problems and expressing solutions.
- A complete set of easy-to-use mathematical tools for algebra, geometry, number sense, statistics, and real-world data collection—all in one package.
- Working documents which can be saved, recalled, edited, and transferred between handheld and computer—and distributed electronically!
- An optimal tool for concept and skill development across the secondary school years.

Table of Contents

Using the TI-Nspire™ Computer Link Software	2
Introducing the Tools	
1. Introducing the Document Model	5
2. Introducing the Calculator Application	9
3. Introducing the Graphs & Geometry Application	13
4. Introducing the Lists & Spreadsheet Application	17
5. Introducing the Notes Application	21
Getting Started Activities	
6. Algebra 1: Points & Lines & Slopes (Oh My!)	25
7. Geometry: Segments in Circles	31
8. Algebra 2: How Fast is the U.S. Population Growing?	37
9. Precalculus: Finding Extraneous Solutions	43
10. Calculus: Derivative Trace	49
Appendix: TI-Nspire™ Learning Handheld Quick Reference Card	56

Using the TI-Nspire™ Computer Link Software

The TI-Nspire™ Computer Link Software enables you to:

- transfer TI-Nspire documents between your computer and a handheld
- capture images from a handheld screen and use them in computer documents
- make a backup of a handheld's documents as a single file on your computer
- update the operating system (OS) software on a handheld

After downloading the TI-Nspire Computer Link Software from TI's website (<http://education.ti.com>) or installing it from the product CD, the following steps will show you how to transfer files between your computer and a handheld.

Opening the TI-Nspire™ Computer Link Software

1. Make sure you have connected a TI-Nspire handheld to your computer.

Note: The TI-Nspire Computer Link Software works with the TI-Nspire handheld only. You cannot use it to communicate with other TI handhelds, such as a TI-89 Titanium™. To communicate with those handhelds, use the TI Connect™ software (version 1.6 or later) instead, available for download from <http://education.ti.com>.

2. Double-click the TI-Nspire Computer Link Software icon on your desktop.
3. Click the handheld to which you want to connect. If a device does not appear, check that your handheld is correctly connected using the black USB direct cable supplied, and powered ON.

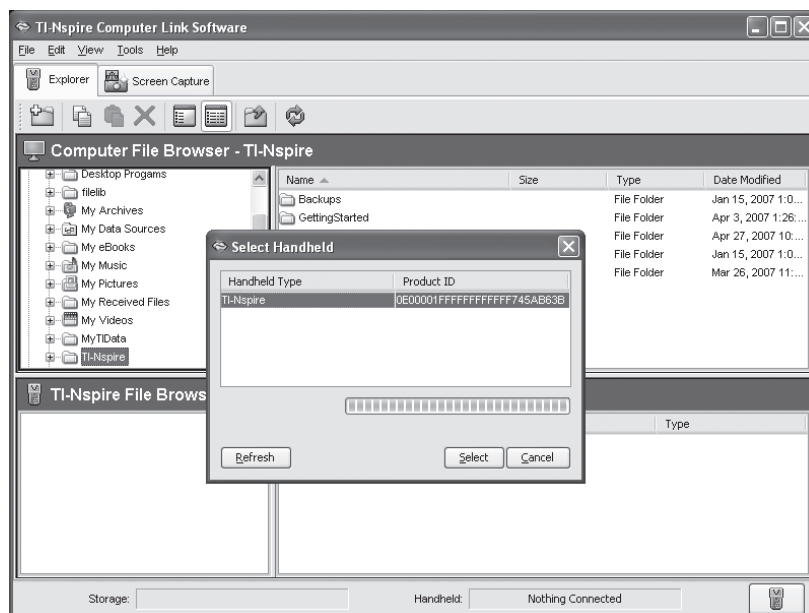

4. Click Select.

You are now ready to transfer the Getting Started .tns files from your computer (top portion of window) to your handheld (bottom portion of window).

Copying Files or Folders by Dragging

You can drag to copy files or folders between a handheld and a computer.

1. Click the file or folder that you want to copy (in this case, navigate to and select the folder titled *GettingStarted* from the product CD using the Computer File Browser, located in the top portion of the window).

Note: You can select multiple files or folders by holding down the **Ctrl** key while selecting.

2. Drag the selection, and drop it on the desired destination (in this case, drag the folder *GettingStarted* to the TI-Nspire File Browser, located in the bottom portion of the window).

Note: If a folder or document of the same name already exists at the destination, you are asked if you want to replace it.

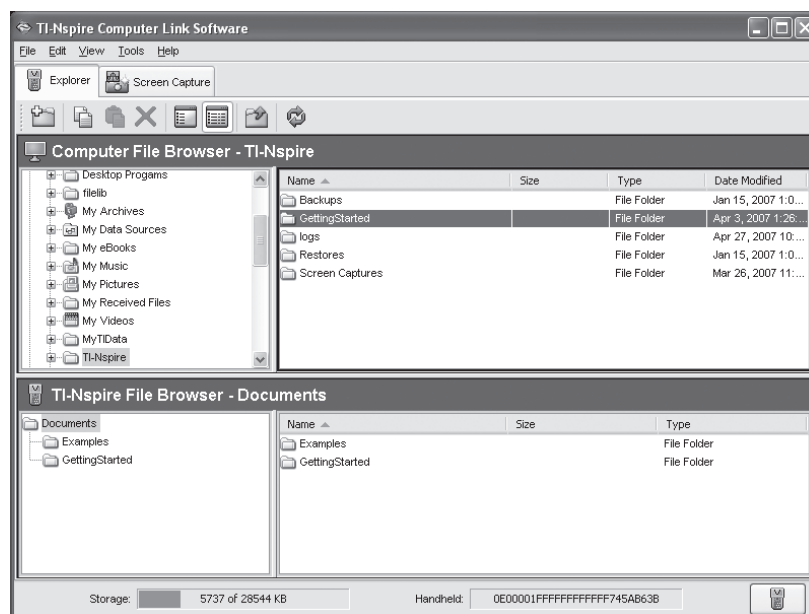

The selected items are now copied to the destination—the Getting Started .tns files are on your handheld.

For more detailed information about using this computer link software, please refer to the TI-Nspire Computer Link Software user guide, available on your product CD or online at <http://education.ti.com>.

INTRODUCING THE TOOLS



TI-nspire™

1. INTRODUCING THE DOCUMENT MODEL

Welcome to an exciting new world for teachers and students of mathematics and science!

In this section, you will be introduced to some of the key features of TI-Nspire™ learning technology, including:

1. understanding the structure of the TI-Nspire document model
2. using menus to create and navigate documents
3. using keyboard shortcuts for accessing menus and menu items

Introduction to Document Management: Quick Start

The TI-Nspire learning handhelds and computer software offer a new experience in teaching and learning technologies for the mathematics and science classrooms. Using these exciting new tools, teachers and students will be able to work seamlessly across representations, documents, and even computer platforms.

It is recommended that you first work through the “Getting Started” tutorial so that you can become familiar with the management and navigation features of the TI-Nspire handheld.

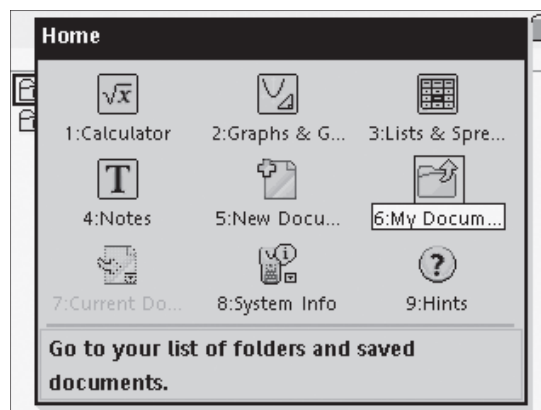

Figure 1.1: The Home Screen

The **HOME** (🏠) key at the top right of the keypad provides immediate access to the main features of the device, including **My Documents**, where documents are organized into folders as they would be on a computer.

Press ▼ on the circular NavPad to move down to the folder titled “GettingStarted.” Press the **ENTER** (⏎) key or ► on the NavPad to open the folder.

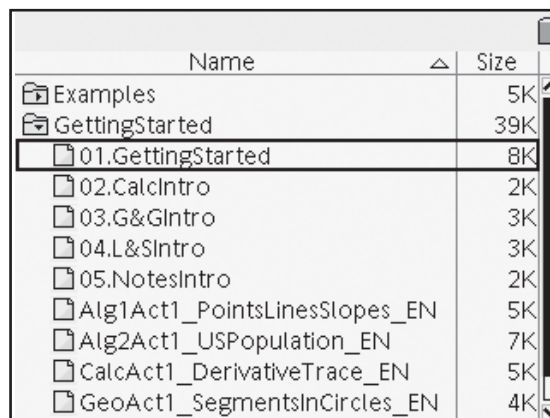



Figure 1.2: Opening a Folder

Use the cursor controls and  to locate and open the file titled “01.Getting Started.”

After opening the document, you will see a screen very much like the one shown in Figure 1.3. Working through this tutorial file will introduce you to many of the key features that define the TI-Nspire document model.











Among these key features are useful and easy ways to *navigate* through documents. For example, pressing the **CTRL** () key and  on the NavPad will take you to the next page in a document. Similarly, pressing  +  returns you to the previous page. Pressing  +  will take you to the **Page Sorter**. Here, you can move quickly and easily through the pages of a document. Pressing  +  once more takes you to **My Documents**.

Figure 1.4 shows the information provided in the Page Sorter view: the name of the **document** (01.GettingStarted.tns), the number of the **problem** that you are currently working in (problem 1), and the total number of **pages** in the problem (for problem 1, 2 pages).

A TI-Nspire *document* may consist of multiple *problems* (each with their own set of *variables*) and each *problem* may consist of multiple *pages*. The document as shown in Figure 1.4 consists of at least two problems, with 2 and 7 pages, respectively.

From the Page Sorter, pressing  +  will return you to single page view, where you can find information at the top of the screen indicating your location in the document. For example, in Figure 1.5, the tab labeled 2.1 is highlighted to indicate that you are on page 1 of problem 2. Current system settings are shown to the right of the tabs.

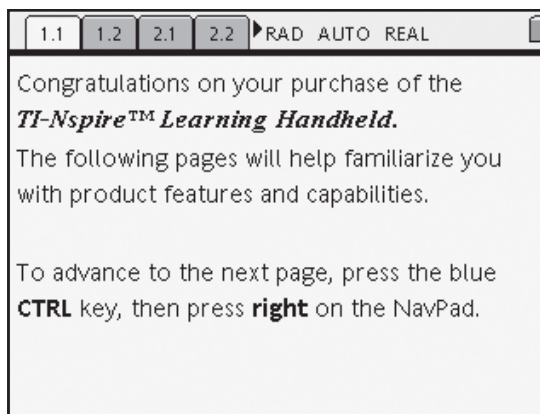

Figure 1.3: A Sample Document

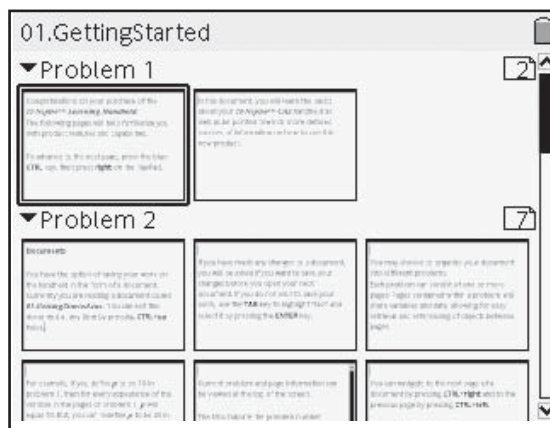

Figure 1.4: Page Sorter View

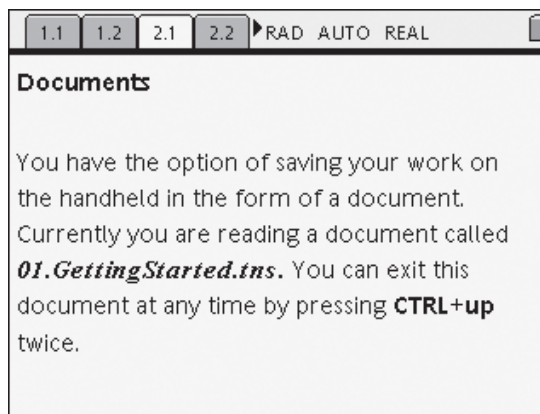

Figure 1.5: Keeping Track of Your Progress

Each page of a document can contain one or more of the core TI-Nspire applications. These applications are:

1. Calculator
2. Graphs & Geometry
3. Lists & Spreadsheet
4. Notes

A page can be divided into as many as four work areas, allowing up to four different applications to be used per page. Figure 1.6 shows a page which has the *Notes* application at the top, and the *Calculator* application at the bottom.

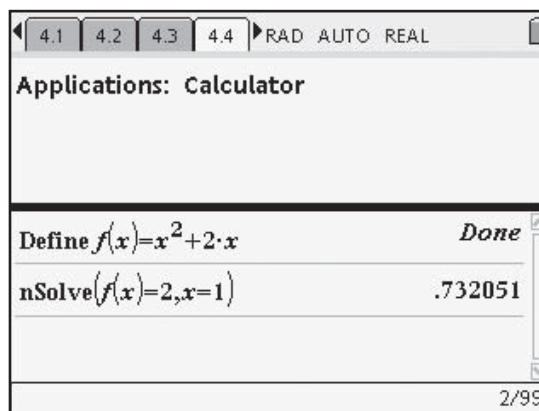

Figure 1.6: A Split Screen

You will learn much more about each of these applications and how they work together in the tutorials that follow. Although you may leave a document at any time, save it, and return to it later, you should continue to work through this *01.GettingStarted.tns* document to learn more.

Locate the **HOME** (🏠) key at the top right corner of the keypad. When pressed, it activates the Home screen: an icon-based view of common tasks as described below.

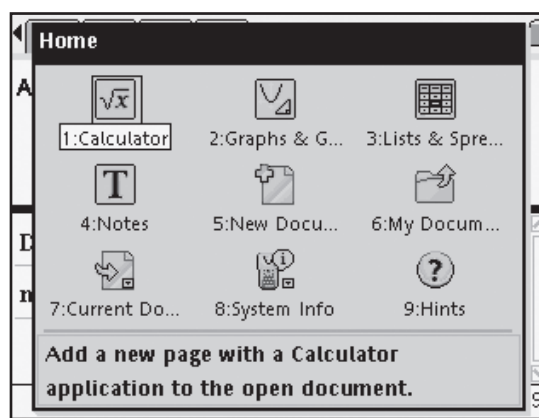

Figure 1.7: Home Screen Icon desktop

Selecting one of the TI-Nspire applications will insert that page into your current document. For example, selecting **1:Calculator** will insert a *Calculator* page.

Pressing **5:New Document** will prompt you to save or discard any changes made to the current document before opening a new one, while **6:My Documents** opens the document browser from which an existing document may be selected.

8:System Info is available here, and pressing **9:Hints** brings up a summary of shortcuts and navigation features as shown in Figure 1.8.

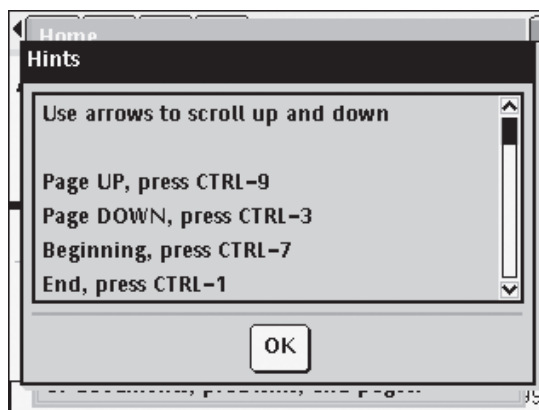

Figure 1.8: Helpful Hints

Return to the Home screen, and select **6:My Documents** to access the document browser. (The current document remains active until you choose to open another document or create a new document, at which time you will be prompted to save or discard any changes you have made.)

The **MENU** (Ⓜ) key, located below the **HOME** key, opens a drop-down menu which provides access to management features of the document browser as shown in Figure 1.9. This **MENU** key will always provide access to the features of the *current* environment. For example, within the *Notes* application, this menu offers only the available options for the *Notes* application.

Press the **ESC** (Ⓜ) key at the top left of the keypad to close out of a menu or dialog box.

Pressing **ctrl** + **Ⓜ** from the document browser accesses a floating contextual menu with commonly-used features required for folder and document management (See Figure 1.10). This feature is context-specific and will offer useful options for the current working environment.

More complete *document management* options are available through the **TOOLS** (Ⓜ) menu. To access the **TOOLS** menu, press **ctrl** + **Ⓜ**. Within any application, this **TOOLS** menu retains the same features as shown in Figure 1.11. Most of the options that are unavailable within the document browser environment (shown in Figure 1.11 as “grayed out”) will be active within an application page in a document.

Let’s now to begin working with a new document and explore our first TI-Nspire application.

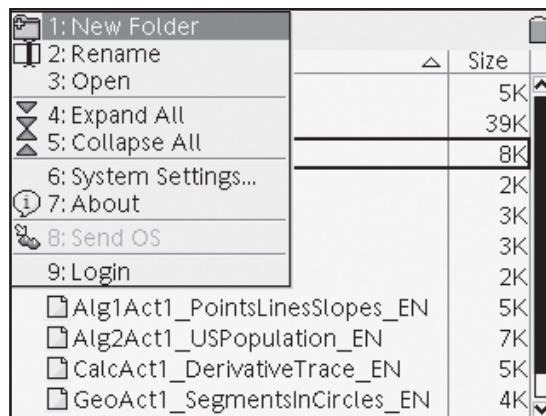

Figure 1.9: Document Browser—MENU

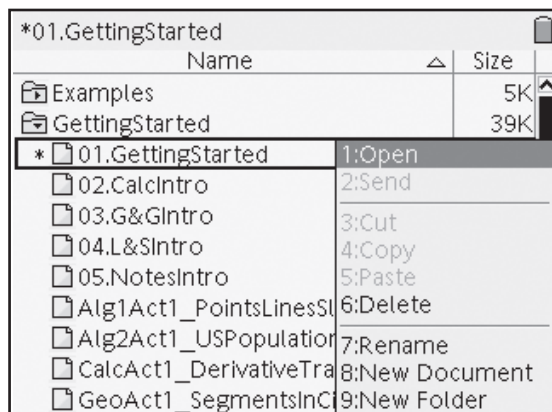

Figure 1.10: Document Browser—CTRL + MENU

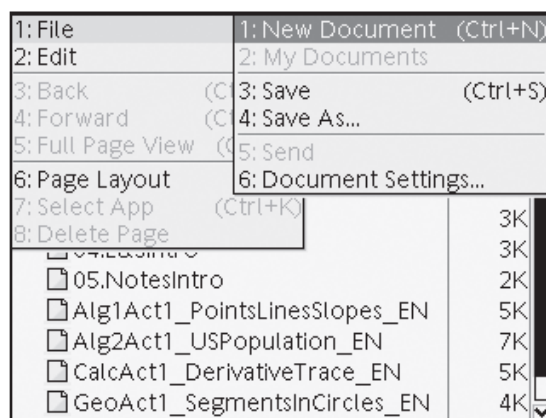



Figure 1.11: Document Browser—TOOLS (CTRL + HOME)

2. INTRODUCING THE CALCULATOR APPLICATION

In this section, you will be introduced to some of the key features of the TI-Nspire[™] **Calculator** application, including:

1. using templates and the Catalog to create mathematical expressions
2. using menu items to carry out mathematical processes, both numeric and algebraic
3. defining functions, variables, and matrices
4. moving between exact and approximate modes of computation

At the heart of TI-Nspire learning technology lies the *Calculator* application, the workspace for both numeric operations and algebra. Create a new document and press  to choose the *Calculator* application. Try recreating the examples shown in Figure 2.1. You can either directly type the commands or explore the menus.

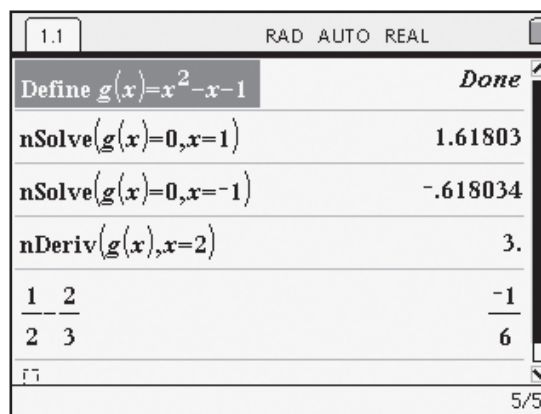





Figure 2.1: The Calculator Application

In this section, we will explore some of the properties of a most interesting number, the Golden Ratio, and in doing so, learn more about the TI-Nspire *Calculator* application.

Insert a new *Calculator* page by pressing  +  (the letter I on the small green buttons) and then pressing . Type "1" using the keypad, and press the **ENTER** key.

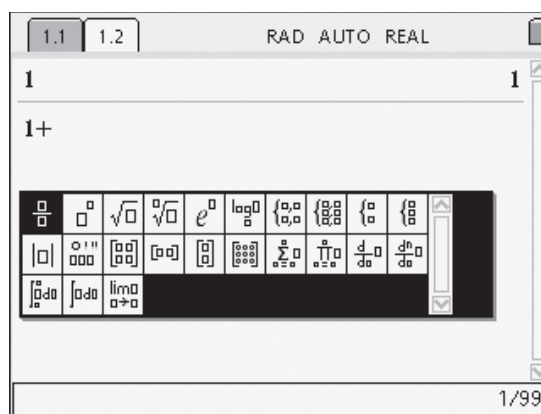







Figure 2.2: Choosing a Template

Now type "1 +" and press  followed by the  key to produce the fraction template.

Alternatively, the **Catalog** () key or  +  (shown in Figure 2.2) will offer access to the templates menu, from which the fraction template may be chosen.

Enter “1” in the numerator position (top of the fraction), and then move to the denominator position (bottom of the fraction) by pressing ▼ on the NavPad or by pressing the **TAB** (tab) key—located below the **ESC** key.

For the denominator, enter “Ans” by pressing (ctrl) followed by (ans) —the white key to the left of the **ENTER** key. Alternatively, you may type “Ans” using the green alphabet keys.

Press (enter) to evaluate the expression.

Pressing (enter) again instructs the device to repeat the last instruction—to find the sum of 1 and the reciprocal of the last answer.

Repeating this simple activity produces a series of fractions which have a very particular pattern. Each fraction is made up of successive terms of the famous Fibonacci Sequence, where each term is the sum of the two previous terms:

1, 1, 2, 3, 5, 8, 13, 21, ...

Can you see these numbers emerging in your fraction calculations?

Something else is happening as this pattern unfolds, but it is not entirely obvious while the results are in exact form. Several options are available for producing approximate answers.

To change the settings for the entire document, press (ctrl) + (tools) to access the **TOOLS** menu (⚙), and then press ► on the NavPad to expand the **File** menu, as shown in Figure 2.5. Arrow down to **6: Document Settings** (or simply press the number 6).

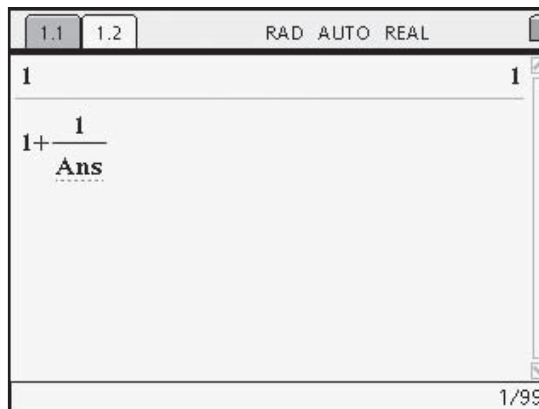

Figure 2.3: Working with Templates

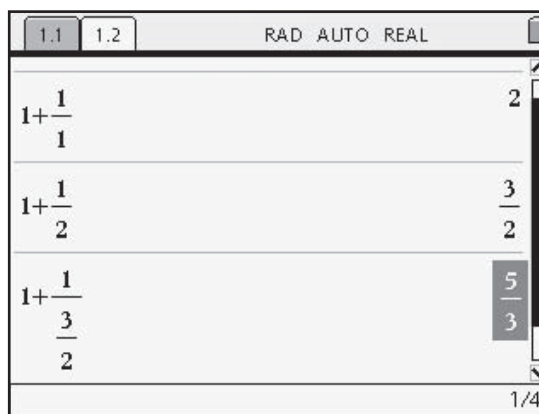

Figure 2.4: Building a Repeated Expression

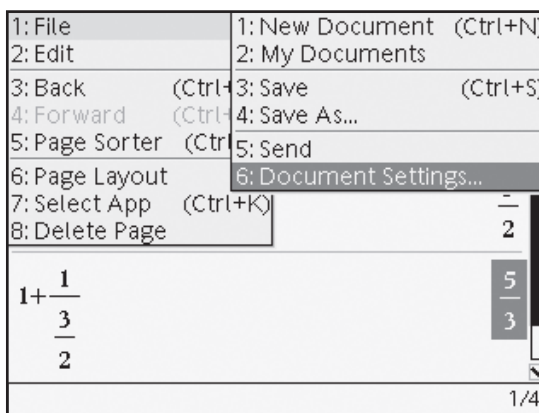

Figure 2.5: Accessing Document Settings

Press tab to move through the settings until the “Auto or Approx.” setting is highlighted. The default setting for this is “Auto,” which allows the device to choose the most appropriate form for an answer. Press \blacktriangledown to access the different options and select “Approximate.” Then press tab again until the “OK” box is highlighted and press enter to confirm your choice.

This changes the setting for the document and subsequent calculations will remain in this mode until it is changed again.

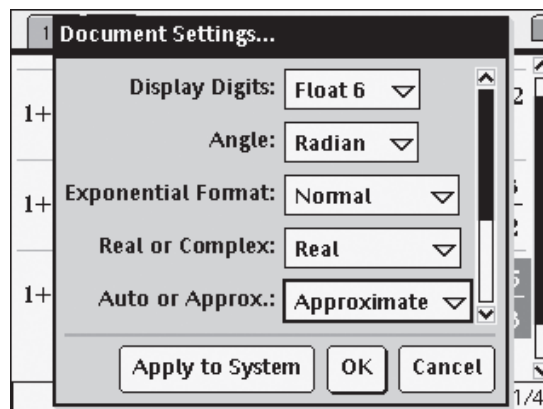

Figure 2.6: Configuring Document Settings

A less permanent option (and the one used in this activity) is to press ctrl before pressing enter to evaluate an expression. This will force an approximate result. Alternatively, entering any numeral in the expression in decimal form (e.g., 1.0 instead of 1) will also force an approximation.

Note that after forcing one approximation, subsequent calculations remain in approximate mode, due to the repeated nature of this calculation and since the *Ans* value is now in decimal form.

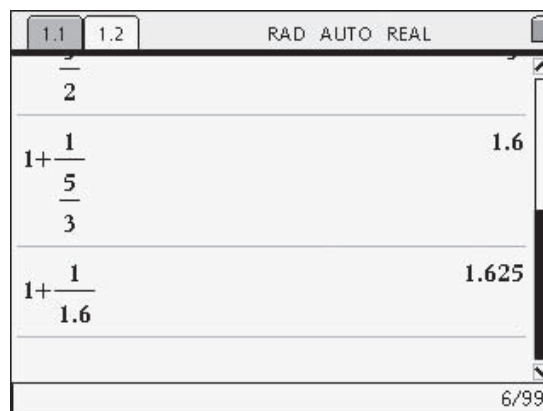

Figure 2.7: From Exact to Approximate

Continue pressing enter to produce a series of numbers which appear to converge to a single result—the famous Golden Ratio!

If a more or less exact result is required, return once more to the Document Settings and change the “Display Digits” menu option.

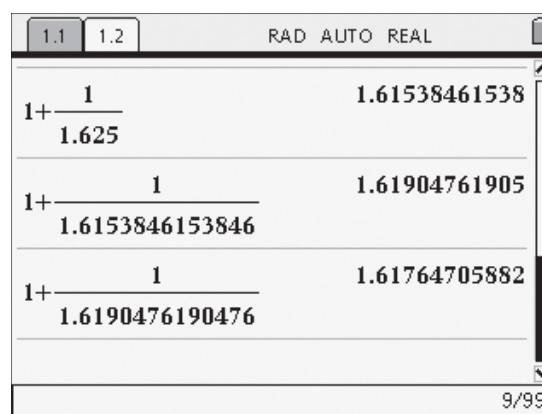

Figure 2.8: Decimal Forms

Interested students may wish to continue the computation until the decimal form remains unchanged, indicating that they have reached the limits of the device's visible accuracy. We say "visible" because, although it will not display more than 12 figure accuracy, another 6 decimal places are used to ensure accuracy of calculation "behind the scenes"!

The Golden Ratio has many interesting properties, both numerical and algebraic. Define the last result as a variable, "gold." To do so, type "Define gold =" and press **▲** on the NavPad to highlight the last calculated answer. Press **⌘** to copy the expression to the entry line, and press **⌘** again to complete the definition.

Now take the reciprocal of *gold*. (You may like to use the keyboard shortcut for the fraction template, introduced earlier!) The result is exactly 1 less than *gold*—the "tail" of the decimal form remains unchanged!

Now find the square of *gold*. (The **SQUARE** (**⌘**) key is halfway down the left-hand side of the keypad. The **CARET** (**⌘**) key moves the cursor into the raised exponent position for entering powers and is located above the **SQUARE** key.) The "tail" is again unchanged, and the result is exactly 1 more than *gold*!

Can you see how both these interesting results may be expressed algebraically? Two different equations can be written from these results and solved as shown in Figure 2.11.

Take some time to explore these interesting numbers further—the Fibonacci Sequence and the Golden Ratio tell us much about nature and art, and there is more yet to be discovered! Using the powerful features available within TI-Nspire learning technology, you have ideal tools for such an investigation!

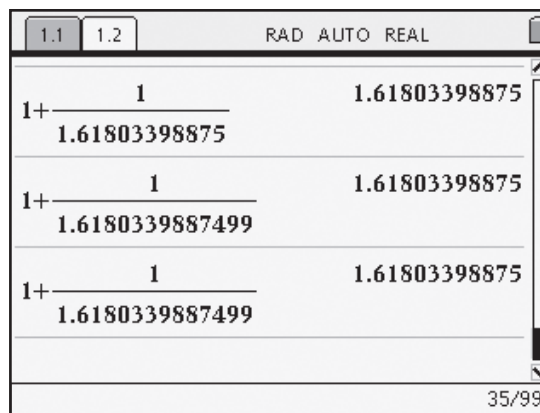

Figure 2.9: Better and Better Approximations

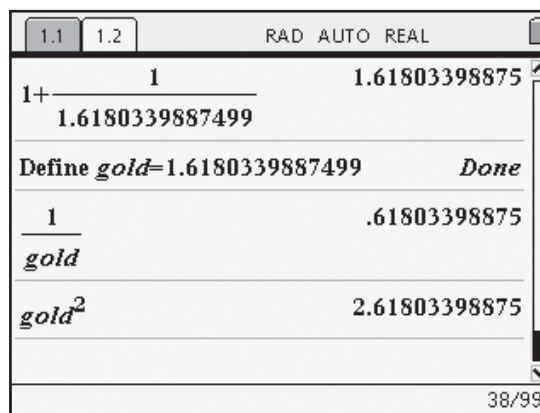

Figure 2.10: Special Properties of "gold"

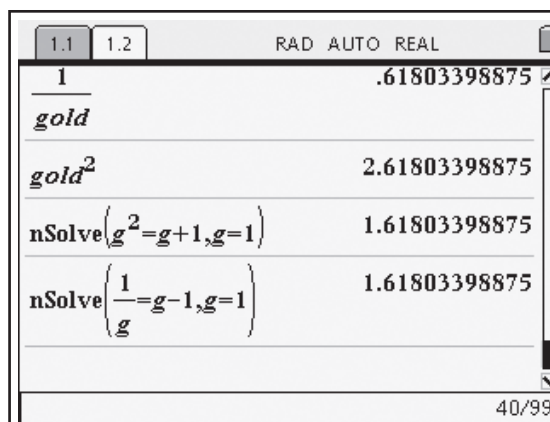

Figure 2.11: Using Numerical Solve

3. INTRODUCING THE GRAPHS & GEOMETRY APPLICATION

The **Graphs & Geometry** application is perhaps the most visually exciting of the TI-Nspire™ applications. In this activity, you will explore some of the functionality of the *Graphs & Geometry* application, including:

1. plotting function graphs
2. examining the graph as a geometric object
3. constructing tangents, perpendiculars, and loci
4. using templates to enter mathematical expressions

This activity was originally developed by Dr. Charles Vonder Embse from Central Michigan University.

Begin with a new TI-Nspire document, and create a *Graphs & Geometry* page. Throughout this activity, you will be pressing MENU to access different tools. While using a tool, its icon will appear in the upper left corner of the screen. When you have finished using a tool, press ESC to close out of it.

From the Points & Lines menu, select the **Point On** tool (---) to create a point on the x-axis, and label this point X. Labeling can be achieved by typing the label immediately after placing the point, or afterwards by using the **Coordinates and Equations** tool ($y=f(x)$) (**MENU > Tools > Coordinates and Equations**). (Note: Unless otherwise directed, do not place points on tick marks; this will cause them to “jump” from mark to mark when dragged, rather than moving continuously along the axis.)

You may wish to use the **Attributes** tool (---) (**MENU > Tools > Attributes**) to change the *style* of the point to increase its visibility.

Next, construct a line through this point that is perpendicular to the x-axis using the **Perpendicular** tool (---) from the Construction menu—again you may use the **Attributes** tool to change the appearance of this line.

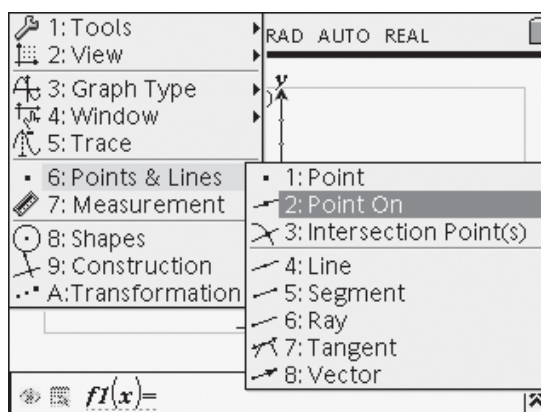

Figure 3.1: Accessing Tools through Menus

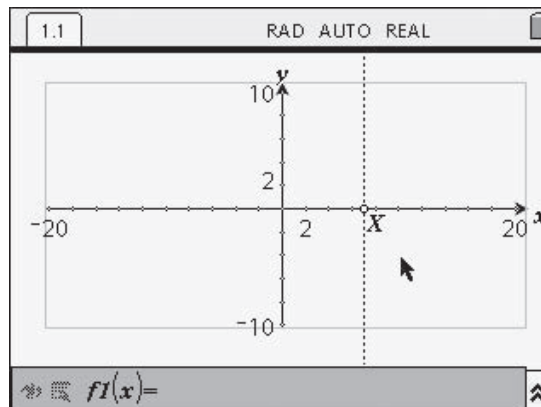

Figure 3.2: Point On an Axis and Perpendicular

Move the cursor to the **Entry Line** and press the **CLICK** (Ⓢ) key to activate it. Enter a cubic function, such as $x^3 - 5x + 2$ (as shown), press Ⓢ to graph it, and press Ⓢ to return to the work area. Now, grab and drag tick marks on the axes to gain a better viewing window for this function.

To grab an object, hover the cursor over it until the object pulses—the cursor should resemble an open hand (☞). Press and hold the **CLICK** key until the cursor changes to a closed hand (☑). Then simply use the NavPad to move the object as desired.

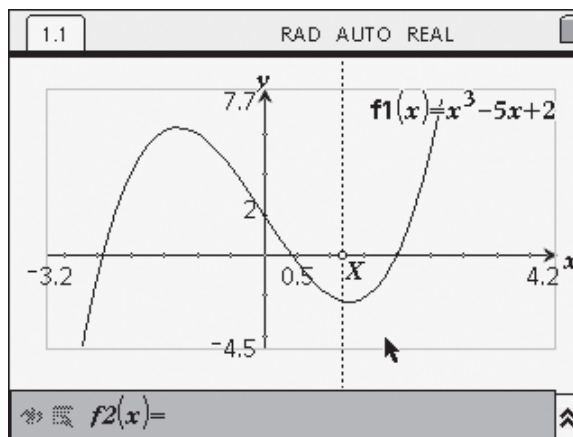

Figure 3.3: Function Graphing and Adjusting Axes

Note that pressing and releasing the **SHIFT** (Ⓢ) key, holding the **CLICK** key, and then dragging allows the axes to be scaled independently. You may also grab and drag the end points of the axes, or type directly into the values at the ends of each axis. **Window Settings** can also be adjusted from the **Window** menu.

From the Points & Lines menu, select the **Intersection Point(s)** tool (Ⓢ) to locate the point at which the line and curve intersect. Label this point *T*.

Pressing Ⓢ + Ⓢ will hide the **Entry Line** at the bottom of the screen to free up some space. (Pressing Ⓢ + Ⓢ again will bring it back.)

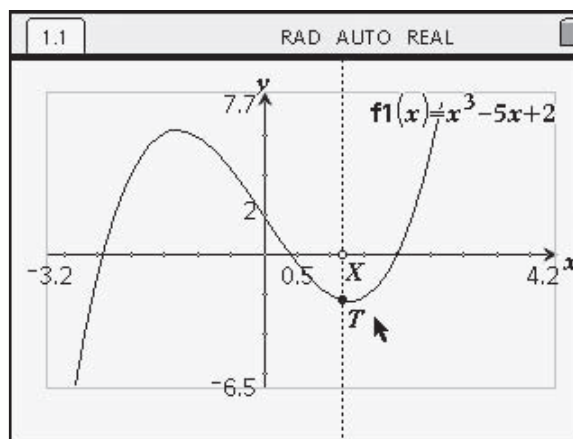

Figure 3.4: Intersection of Perpendicular and Curve

Next, create a dynamic tangent to the curve at point *T* by using the **Tangent** tool (Ⓢ) from the Points & Lines menu.

From the Measurement menu, select the **Slope** tool (Ⓢ) to measure the slope of the tangent line. You may wish to move the slope to a convenient place on the screen, such as the lower right corner. Because this value will, of course, dynamically change as point *X* is dragged, it is beneficial to have it in a fixed position so you know where to find it.

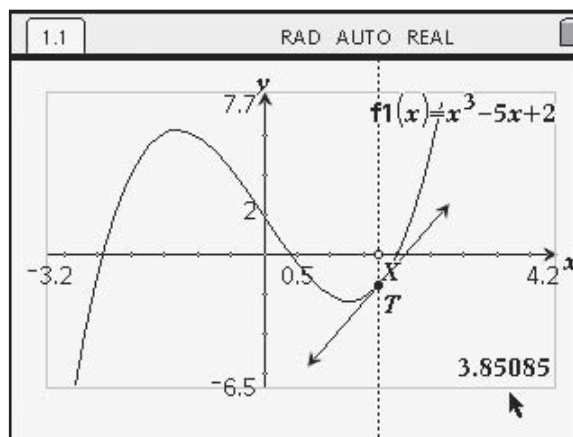



Figure 3.5: Adding a Dynamic Tangent

The **Measurement Transfer** tool (, available from the Construction menu, allows calculated measurements to be transferred to lines, segments, rays, and other geometric figures. Then, as the original figure's measurements change, so will the transferred measurement.

Select the **Measurement Transfer** tool and click on the slope measurement as shown in Figure 3.6. Then click on the y -axis. This creates a point on the y -axis such that the distance from the origin to the point is equal to the slope of the tangent line!

Press **(esc)** to close out of the **Measurement Transfer** tool, and use the **Perpendicular** tool to create a perpendicular line to the y -axis that passes through this newly constructed point. (Again, you may wish to use the **Attributes** tool to change this line's appearance.) Now use the **Intersection Point(s)** tool to find and label point P , the intersection of the two constructed perpendicular lines.

As you drag point X along the x -axis, study the movement of point P , and try to describe the path it takes. Explain what point P represents in terms of the constructions.

After some discussion, select the **Locus** tool () from the Construction menu. Clicking on point P and then on point X will generate the path of the set of *all* points P as the point X is moved along the axis.

Further discussion should center on the nature of this new curve, which was *derived* from the original curve by graphing the slope at each point of the domain.

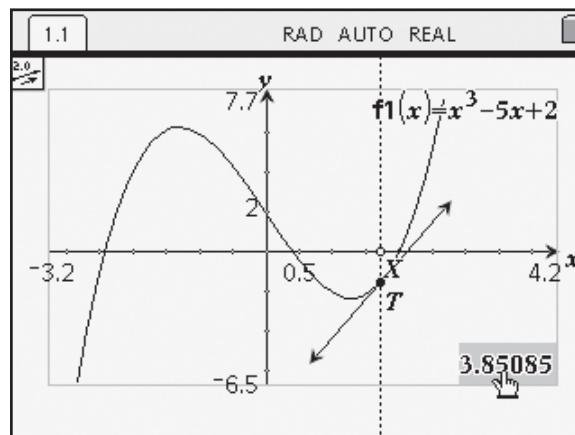

Figure 3.6: Measurement Transfer Tool

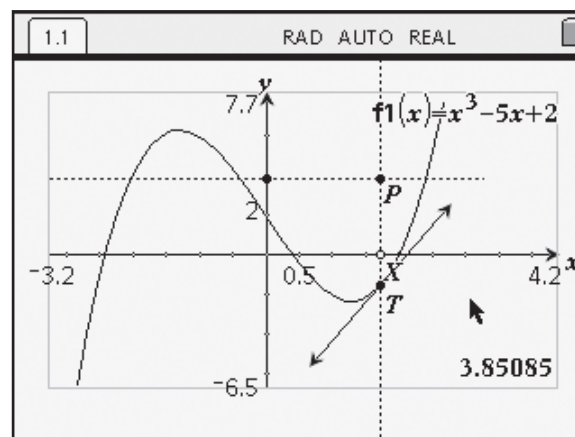

Figure 3.7: Intersection of Perpendiculars

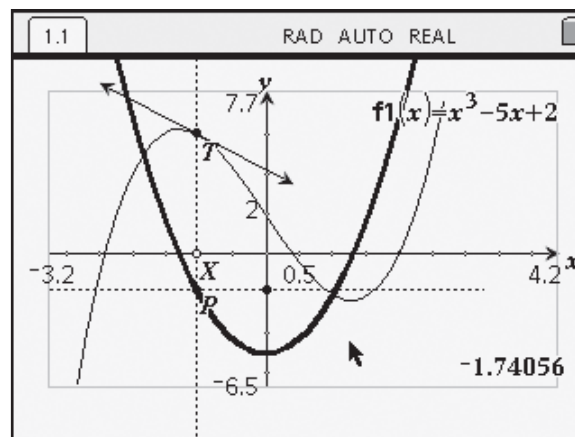

Figure 3.8: Locus of the Tangent Slope

Unhide the **Entry Line** and enter x^2 in for **f2(x)**. Grab the graph of this parabola near the origin (the cursor should look as shown in Figure 3.9: \oplus) and drag its vertex to match that of the derived function you have created using the **Locus** tool. Note that the equation updates as the curve is translated.

You may also double-click the function label for **f2(x)** on the graph which opens the function in a text box, ready to edit.

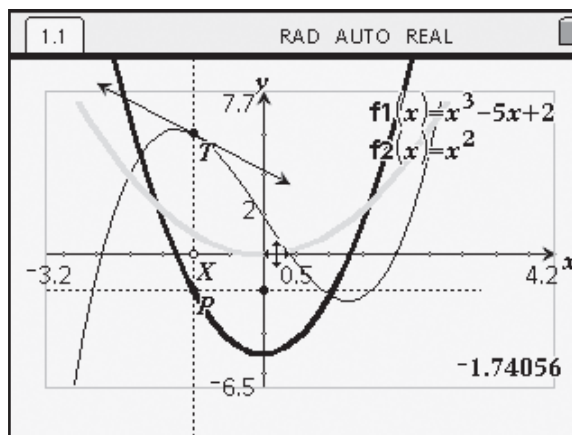

Figure 3.9: Translating a Function

Grab one of the arms of the parabola (now the cursor should look as shown in Figure 3.10: ∇) and drag to stretch until it closely matches the curve. The equation again updates as the curve is stretched. Try adjusting the function equation to better match your curve!

After further discussion, the equation of the derived function may be recognized as $3x^2 - 5$. How might this be found from the original function?

Now, you can alter the equation for **f1(x)** and observe how it affects the graph of the derived function. Then attempt to find the equation of the derived function by starting with a fundamental function and dragging and stretching.

Explore and enjoy!

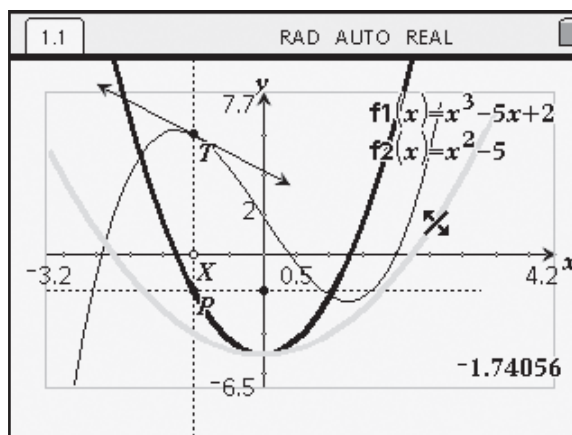

Figure 3.10: Stretching a Function

4. INTRODUCING THE LISTS & SPREADSHEET APPLICATION

The **Lists & Spreadsheet** application is one of the four core TI-Nspire[™] applications. In this activity, you will analyze data using the some of the functionality of the **Lists & Spreadsheet** application, including:

1. entering data into lists
 2. naming lists
 3. using formulas
 4. determining regression equations
-

Scenario

Although airships are still used for aviation including advertising blimps over sporting events, sightseeing rides, and heavy lifting, there are still concerns by the public about their safety. This is mostly due to the historic case of a Zeppelin exploding in 1937—known as the *Hindenburg disaster*. Currently a safer gas, helium, is used rather than hydrogen gas, which was the gas used in the early Zeppelin airships.

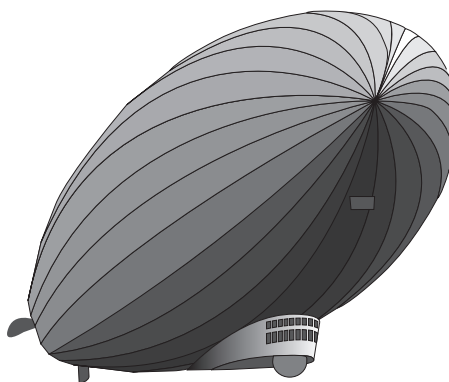

The table below shows how the volume of hydrogen gas affects the pressure when the temperature is kept at 27°C.

Volume (liters)	Pressure (atm)
1.25	20
0.84	30
0.63	40
0.51	50
0.26	100

It is clear from the above data and our own understanding that if the space (volume) of the gas is decreased the pressure will increase. We will investigate the mathematical relationship between the pressure and the volume of hydrogen gas.

Step-by-Step Instructions

Open a new document and insert the *Lists & Spreadsheet* application. From the Actions menu, select **Resize** and press \blacktriangleright on the NavPad to make each of the first three columns wider.

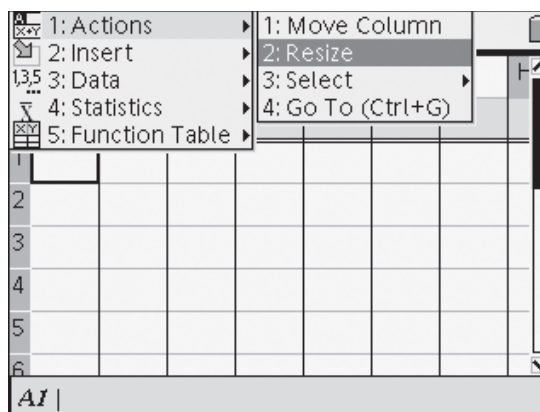

Figure 4.1: A New Lists & Spreadsheet Page

Move the cursor into the heading space of Column A and type in *volume* as the List name. Press enter . Type in *pressure* as the List name for Column B. Press enter .

In Column A, enter the *volume* readings from the table on page 17. In Column B, enter the *pressure* readings.

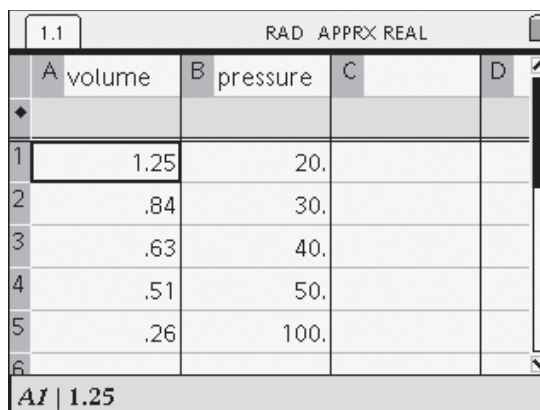

Figure 4.2: Entering Data

According to Boyle's Law for an ideal gas, pressure varies inversely with volume. That is, for a set amount of gas, the lesser the volume, the greater the pressure:
 $P \propto \frac{1}{V}$. This means that $P = \frac{k}{V}$ or
 $P \times V = k$ (where k is some constant).

Create a formula in Column C to multiply the two lists, *volume* and *pressure*, as follows. Move the cursor to the formula cell (in gray) in Column C and press = . Then press the **VAR** (VAR) key and **Link to** the *volume* variable. Insert the multiplication sign (press MIS) and use the **VAR** key again to **Link to** the *pressure* variable. Press enter to populate the column.

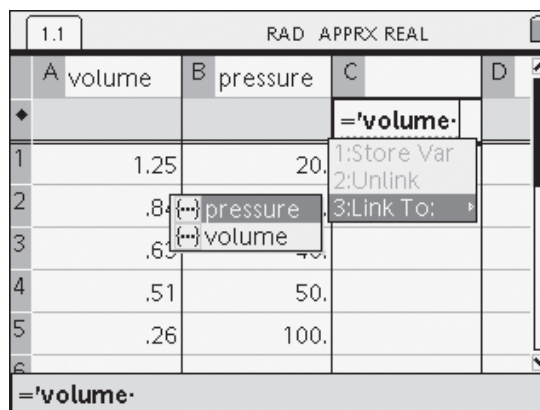

Figure 4.3: Entering a Formula

Does the data support Boyle's law? (Are the values in Column C constant?)

If the data is in fact related by $P = \frac{k}{V}$, then a power regression should show $P = kV^{-1}$.

	A volume	B pressure	C	D
			=volume*pr	
1	1.25	20.	25.	
2	.84	30.	25.2	
3	.63	40.	25.2	
4	.51	50.	25.5	
5	.26	100.	26.	
6				

C | =volume*pressure

Figure 4.4: Interpreting Results

To perform a regression, highlight Columns A and B by choosing **MENU > Actions > Select > Select Column**, and then hold down the **SHIFT** (CAPS) key and arrow over to select both columns. Alternatively, you can move the cursor to the top of Column A, press \blacktriangle on the NavPad to select Column A, hold down the CAPS key, and press \blacktriangleright to extend the selection to include Column B.

	A	B	C	D
1	1.25	20.	25.	
2	.84	30.	25.2	
3	.63	40.	25.2	
4	.51	50.	25.5	
5	.26	100.	26.	
6				

Figure 4.5: Selecting Columns

From the Statistics menu, select **Stat Calculations**. Note that there are numerous different regressions that may be performed on a set of data. For this activity, we wish to perform a **Power Regression**.

	A	B	C	D
1	1.25	20.	25.	
2	.84	30.	25.2	
3	.63	40.	25.2	
4	.51	50.	25.5	
5	.26	100.	26.	
6				

Figure 4.6: Performing Statistical Calculations

Note that the Column names a[] and b[] are shown rather than the List names. You can choose the List names if you prefer by pressing ▼ on the NavPad. Press (tab) to move down to the “1st Result Column” option. Because we have data in Column C, you need to direct the regression equation to fill Column D by changing “c[]” to “d[]”. Notice that the options as they are set will save the regression equation to f1.

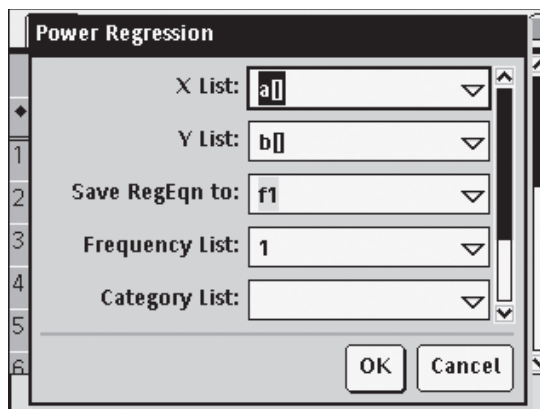

Figure 4.7: Setting Up a Regression

You may wish to resize Columns D and E to view the results of the regression. The regression equation of $P = 25.07V^{-1.03}$ is quite acceptable as an approximation of $P = kV^{-1}$ and thus the data supports Boyle’s Law.

	D	E	F	G
1	25. Title	Power Reg...		
2	25.2 RegEqn	a*x^b		
3	25.2 a	25.0678		
4	25.5 b	-1.02524		
5	26. r²	.999961		
6				

E2 | ="a*x^b"

Figure 4.8: Results of a Power Regression

You can plot this data along with the regression function in the *Graphs & Geometry* application. Press (ctrl) + (i) and insert a new *Graphs & Geometry* page.

Draw a scatter plot of Volume vs. Pressure (MENU > Graph Type > Scatter Plot). Press (enter) to choose the x-variable (select volume), press (tab), then press (enter) to choose the y-variable (select pressure). Adjust the window (MENU > Window > Zoom – Stat), and plot the regression equation (MENU > Graph Type > Function)—press ▲ on the NavPad to access f1(x), and press (enter) to draw its graph.

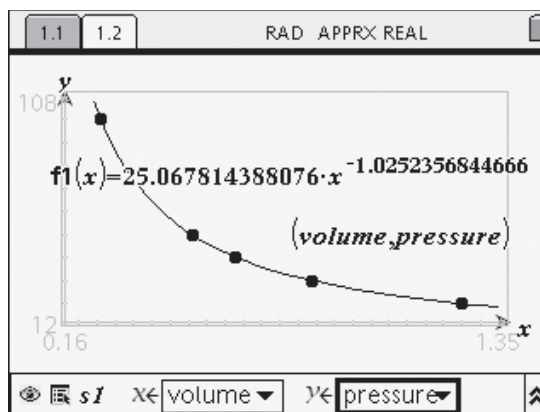

Figure 4.9: Graphical Results

Hydrogen might be close to an “ideal gas” but is it *ideal* for an airship?

5. INTRODUCING THE NOTES APPLICATION

In this section, you will be introduced to some of the key features of the TI-Nspire™ **Notes** application, including:

1. entering and accenting text
2. using templates for Questions/Answers and Proofs
3. using the Symbol Palette to enter mathematical terms
4. evaluating mathematical expressions

A unique feature of this new and exciting tool is the TI-Nspire **document model**. Previously when working with handheld devices, users would enter and perform calculations, and then record results and explanations elsewhere, in workbooks or even examination papers.

With TI-Nspire learning technology, the user can begin by creating a new document, and directly record all work in the same electronic file, providing a complete documentation of their mathematical activities. Using the *Notes* application, problems may be posed and solved, reasoning may be recorded, and mathematical thinking may be made public!

There are a variety of ways that users can format text to accentuate important aspects of their documents and to produce text that is richly presented. Bold (**Keyword**), underline (Title), and italics (*Sub-heading*) options are available via the Format menu, as are superscript and subscript options.

These documents may be readily shared with others—teachers or other students, whether in handheld or computer-based environments. *TI-Nspire* documents may be transferred seamlessly across platforms!

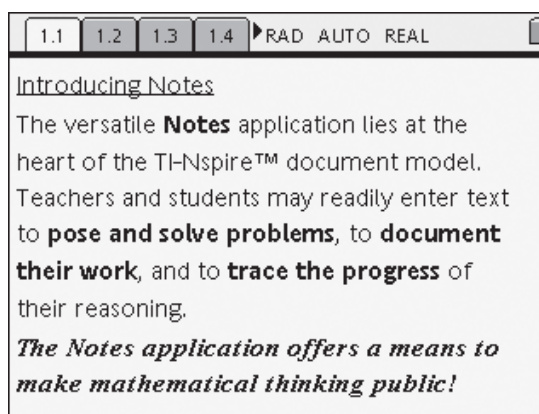

Figure 5.1: Introducing Notes

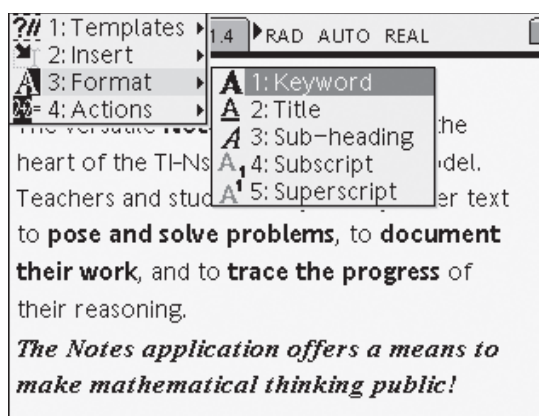

Figure 5.2: Accenting Text

The *Notes* application offers templates for presenting and organizing these documents. In addition to free-text pages as shown in Figure 5.1, users may choose the **Q&A** format as shown in Figure 5.3. This format allows teachers (or students) to pose questions, and record answers. Of course, these answers may be hidden if desired!

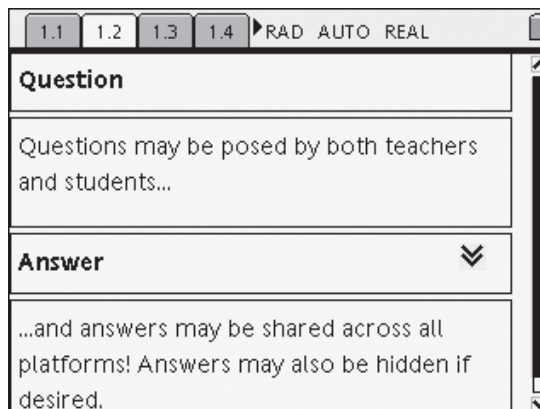



Figure 5.3: Q&A Template

The **PROOF** format is ideally designed, not only for geometric proof, but for all manner of logical argument. Choosing **Shape** from the Insert menu (or using the **Catalog** () key) offers a range of geometric symbols which satisfy a long-recognized need for a simple and convenient way for entering and representing geometric proofs.

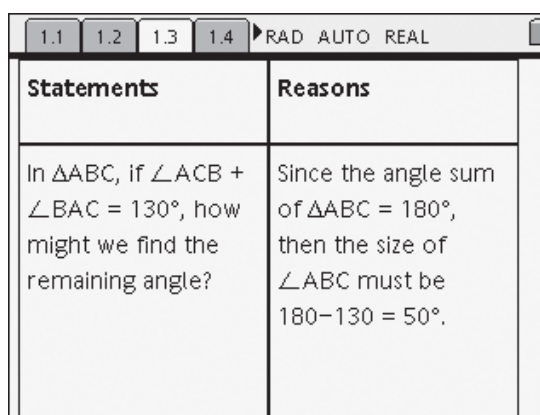

Figure 5.4: Proof Template

This format supports and encourages students to make mathematical statements of all kinds, and to develop arguments to justify their ideas.

Perhaps the most remarkable feature of this apparently simple application is that, like all other TI-Nspire working environments, *Notes* is **mathematically active!**

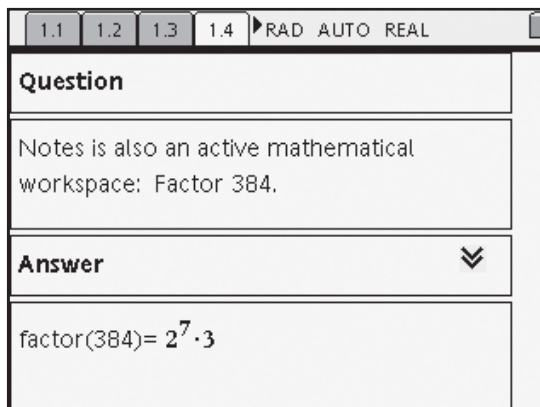



Figure 5.5: Mathematically Active Documents

Mathematical expressions and equations may be entered using the **Catalog** () key and symbol palette (or simply typed), highlighted, and then evaluated using **MENU > Actions > Evaluate Selection**.

One way in which this powerful feature may be used involves entering a mathematical expression (as shown in Figure 5.6), highlighting, and then *copying* the expression (using the shortcut $\text{ctrl} + \text{C}$). This may be pasted on the next line (using the shortcut $\text{ctrl} + \text{V}$), and then evaluated, displaying both input and output for each computation.

Using **MENU > Insert > Expression box**, correct mathematical formatting is available, in addition to a range of geometric shapes.

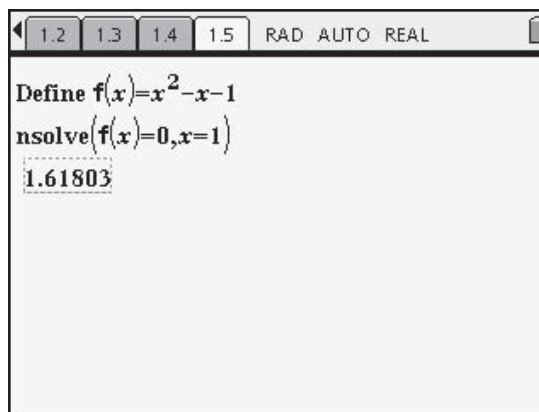

Figure 5.6: Correct Mathematical Formatting

Finally, the *Notes* application offers the option for users to take on different roles, distinguishing, if desired, between the role of “Teacher” and “Reviewer” (**MENU > Insert > Comment**). In this way, documents may be developed in a collaborative manner between student peers and teachers!

The *Notes* application offers teachers and students a simple and yet powerful means of annotating their mathematical documents to produce, not only a professional appearance, but a true record of their mathematical thinking and activities.

TI-*nspire*™

GETTING STARTED ACTIVITIES



Points & Lines & Slopes (Oh My!)

ID: 8106

Time required

45 minutes

Activity Overview

Students are introduced to the key concepts of the Cartesian plane by moving a point around the coordinate plane and investigating the coordinates of the point in different quadrants as well as on each axis. They will also look at the relationship between the coordinates of a point and the distance of the point from each axis. Later, they will explore overlaying a line on two points in the plane, and investigate the relationships of lines, slopes, and equations. The investigation will continue with parallel and perpendicular lines and their slope relationships.

Concepts

Points, Lines, Slope, Graphs of Linear Equations, Parallel/perpendicular lines

Teacher Preparation

This investigation offers many possible extensions depending on the level of the student. The activity can be used in the middle grades and even in later elementary grades.

- At the PreAlgebra level, this activity can be used to introduce or review properties of points in the coordinate plane.
- At the Algebra 1 level, this activity can review coordinates and then go on to introduce or review the relationships of points, lines, slopes, and equations. The graph could also be divided into different zones by graphing $f(x) = x$ and $f(x) = -x$ and having students generalize the slope for each of these zones.
- At the Algebra 1 level, after graphing lines and looking at relationships, another point could be placed on the plane and students could look at the coordinates of the point with respect to the line. This could be used to introduce inequalities.
- In Geometry, angles could be measured along with the parallel or perpendicular lines to begin the discussion of proving lines parallel by using measurement of angles. This activity could also provide the opportunity to prove algebraically, as well as geometrically, the slope relationship of perpendicular lines.
- The screenshots on pages 26–29 (top) demonstrate expected student results. Refer to the screenshots on page 29 (bottom) for a preview of the student .tns file.
- **To download the .tns file and student worksheet, go to <http://education.ti.com/exchange> and enter “8106” in the search box.**

Classroom Management

- This activity is intended to be **teacher-led**. You may use the following pages to present the material to the class and encourage discussion. Students will follow along using their handhelds, but the majority of the ideas and concepts are only presented in **this** document. Be sure to cover all the material necessary for students' total comprehension.
- The student worksheet is intended to guide students through the main ideas of the activity, while providing more detailed instruction on how they are to perform specific actions using the tools of TI-Nspire handhelds. It also serves as a place for students to record their answers. Alternatively, you may have the class record their answers on a separate sheet of paper, or just use the questions posed to engage a class discussion.

TI-Nspire™ Applications

Graphs & Geometry, Notes

Three focus questions define this activity (Some discussion should follow the posing of these questions):

1. *What are the relationships of the coordinates of points with various locations in the Cartesian plane?*
2. *What is the relationship of a line with its slope, equation, and y-intercept?*
3. *What is the relationship between the slopes of parallel or perpendicular lines?*

Problem 1 – Investigating the coordinates of points

Step 1: Direct students to open page 1.2, where they will find a *Graphs & Geometry* page with the function entry line hidden. Instruct students to place and label points *P* and *Q* anywhere in the coordinate system using the **Point** tool (•) from the Points & Lines menu. (The labels *P* and *Q* may be typed directly after placing each point.) Then have students label the coordinates of each point, by selecting **MENU > Tools > Coordinates and Equations**.

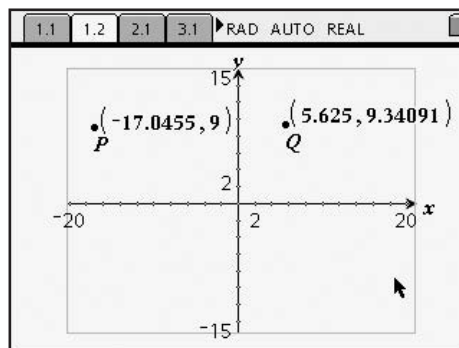

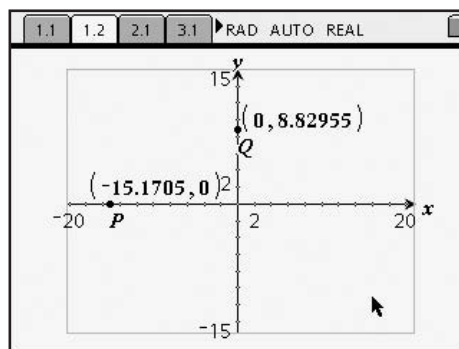

Step 2: Next have students **Redefine** (available from **MENU > Tools**) point *P* to the x-axis and point *Q* to the y-axis. (Students should be instructed to **not** redefine to a tick mark on the axis.) Have students now drag point *P* and answer questions from the worksheet about x-intercepts. (This foreshadows two important concepts later: x-intercepts of graphs and equations of vertical lines.) Next, have them drag point *Q* and answer questions about y-intercepts. (This foreshadows the concept of the y-intercept of a graph.)



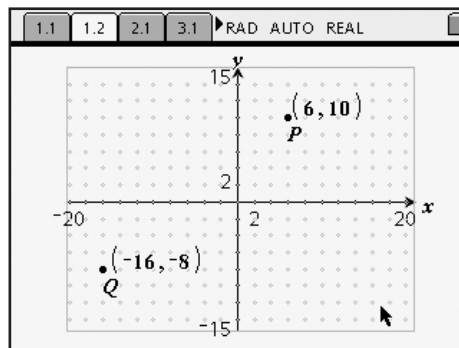

Step 3: After dragging points *P* and *Q*, have students show the grid by selecting **Show Grid** from the View menu. Next, they should again redefine points *P* and *Q*, this time to grid points. The coordinates are now integer values. Have students once again drag points *P* and *Q* around the plane and answer the questions on their worksheet about the sign of the x- and y-coordinates in each quadrant.

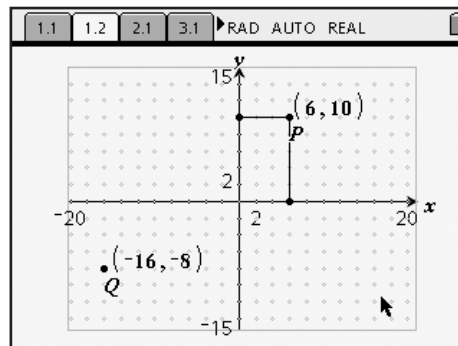

Step 4: Students should now be able to make sense of exactly what the coordinates should be in different quadrants as well as on each axis. Give students the coordinates of a point and ask which quadrant it is in and visa versa. This simple activity is good for students to develop their technology skills and establish sign patterns for the four quadrants.

Step 5: Have students use the **Perpendicular** tool () (**MENU > Construction**) to construct perpendiculars through point P to each axis. After the perpendiculars are in place, direct students to construct segments from point P to each axis (**MENU > Points & Lines > Segment**) and then hide the “excess” perpendicular lines using the **Hide/Show** tool () , available from **MENU > Tools**.



Step 6: Now have students measure the length of each segment using the **Length** tool () from the Measurement menu. Drag point P and have students conjecture about the distances and the coordinates. (There is a one-to-one correspondence between the distances from P to each axis and the absolute value of the coordinates of P .)

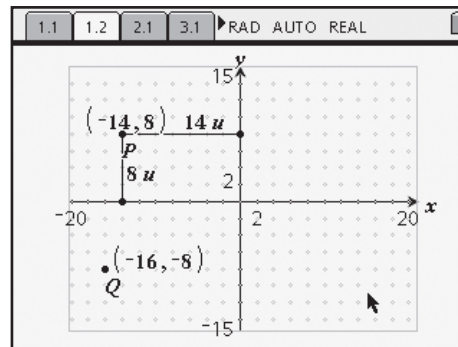

Problem 2 – Investigating lines, equations, and slopes

Step 1: In Problem 2, students are given points P and Q . (These points are not attached to the grid to allow for more exploration.)

If this is students’ first introduction to slope, provide a brief description of the concept, including “rise over run.” Ask students to visualize a line between points P and Q and conjecture as to whether the slope is positive or negative, small or large, etc. Then have them draw a line through points P and Q using the Line tool () from the Points & Lines menu.

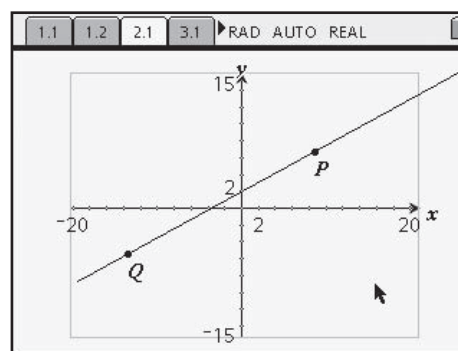

Step 2: Next, have students find the slope (**MENU > Measurement > Slope**) and equation (**MENU > Tools > Coordinates & Equations**) of the line. Have them label the slope measurement as shown at right by clicking in the text box and typing **slope=**. Also, they can decrease the number of digits of the slope by hovering the cursor over the measurement and pressing $\left\langle \frac{\square}{\square} \right\rangle$.

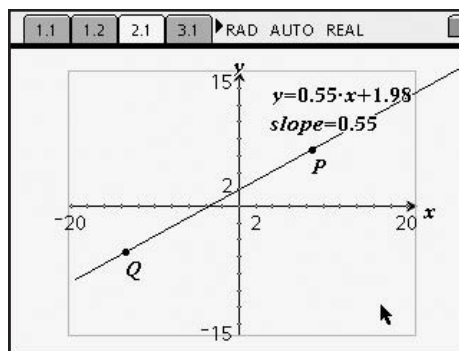

Step 3: Now students can investigate the relationship of the line with its slope and equation. First have students drag point P or Q and notice what changes and what does not. Next drag by the line itself and observe what changes. Students should also drag point Q to the y-axis (or redefine it to the y-axis) to investigate the relationship between a line's y-intercept and its equation.

Problem 3 – Investigating the slopes of parallel and perpendicular lines

Step 1: On page 3.1, students are given two parallel lines, their equations, and their slopes. (This construction is done for them. An alternative would be for the students to construct the parallel lines, show the slopes, and explore.) Students should explore the relationships of parallel lines and slopes while they drag the original line by one of its defining points, P or Q.

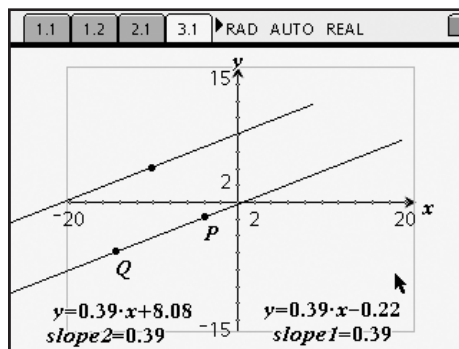

Step 2: On page 3.2, students are shown two perpendicular lines, their equations, and their slopes. Again, students could be led through this construction, if desired. Encourage students to drag the lines around and try to identify the relationship between their slopes.

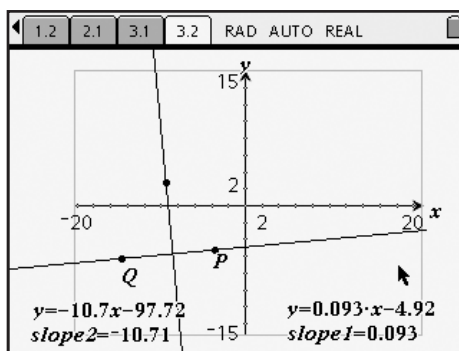

Step 3: Another way to look at the relationship of the slopes is to find the product of the two slopes. Have students select **MENU > Tools > Text**, press $\frac{\approx}{\text{enter}}$ in an open space in the work area, and enter “a*b” (or any other two variables). Next, they should select **MENU > Tools > Calculate**, position the cursor over the newly created text box, and press $\frac{\approx}{\text{enter}}$. Moving the cursor off of the text box, students are prompted for the value of the variables. Clicking on each of the measured slopes will produce the product—have students drag it to a convenient location on the screen. Finally, have students drag the line through points *P* or *Q* by grabbing and dragging either point. Encourage them to notice what happens to the product as the lines change!

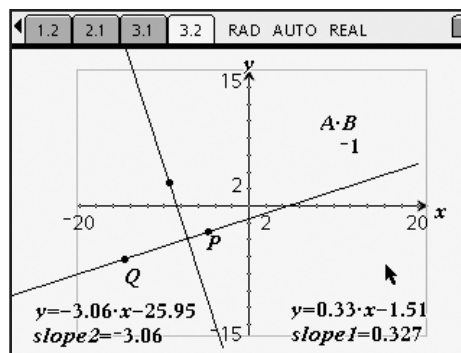

Extensions

As stated in the teacher preparation, there are many extensions to this activity depending on the level of the student. This activity can easily be manipulated to lead students into a deeper study of slopes, parallel lines, and proofs.

Points & Lines & Slopes (Oh My!) – ID: 8106

(Student)TI-Nspire File: Alg1Act1_PointsLinesSlopes_EN.tns

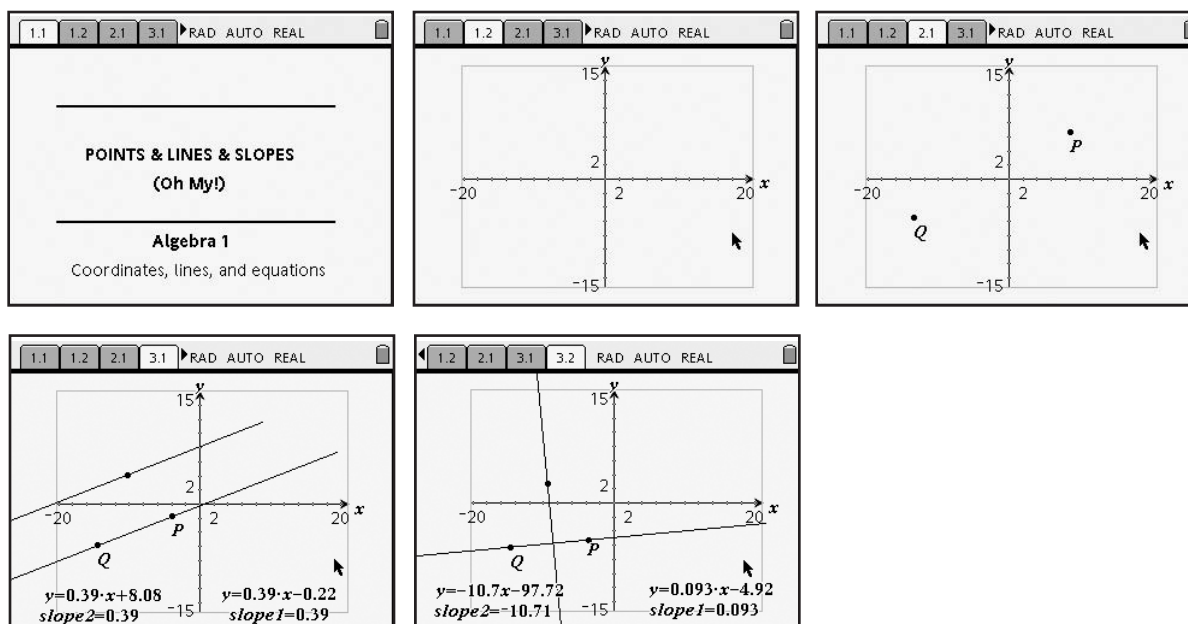

Segments in Circles

ID: 8107

Time required

45 minutes

Activity Overview

In this activity, students will explore the relationships among special segments in circles. The special segments include tangent segments, segments created by two intersecting chords, and secant segments. Students will store variables and use both the automated and manual data capture features in a spreadsheet and write formulas in spreadsheets to confirm relationships among segments.

Concepts

- Tangents and secants
- Tangent segments and secant segments
- Chords

Teacher Preparation

This activity is designed to be used in a high-school geometry classroom.

- Students should already be familiar with parts of a circle, including tangents and secants. If needed, introduce the following terms: tangent segment, secant segment, internal secant segment, and external secant segment.
- Remind students that secants and tangents are lines and because lines continue indefinitely, they **cannot** be measured. Segments are parts of lines and the distances between their endpoints **can** be measured.
- This activity assumes a basic working knowledge of the TI-Nspire device, such as drawing shapes and finding lengths of segments.
- Due to the amount of memory that is taken up by using automated data capture, it is recommended that students either not save this file when they are finished or that they clear the data from the spreadsheet before saving (by pressing ENTER twice in the formula cells of the columns containing the data).
- The screenshots on pages 32–35 demonstrate expected student results. Refer to the screenshots on page 36 for a preview of the student .tns file.
- **To download the .tns file and student worksheet, go to <http://leducation.ti.com/exchange> and enter “8107” in the search box.**

Classroom Management

- This activity is intended to be mainly **teacher-led**, with breaks for individual student work. Use the following pages to present the material to the class and encourage discussion. Students will follow along using their handhelds.
- The student worksheet helps guide students through the activity and provides a place for students to record their answers.
- Information for an optional extension is provided at the end of this activity, both on the student worksheet and in the .tns file. Should you not wish students to complete the extension, you may delete the extension from the .tns file and have students disregard that portion of the student worksheet.

TI-Nspire™ Applications

Graphs & Geometry, Lists & Spreadsheet, Notes

This activity allows students to interactively discover, confirm, and explore the theorems that describe the relationships involving different segments in circles. You may need to help students use the handheld's different tools; instructions are provided in this document at point of first use.

Problem 1 – Chords and tangents

Step 1: Have students use the **Circle** tool (⊙) from the Shapes menu to draw a circle on page 1.2. Then instruct them to draw two tangents (**MENU > Points & Lines > Tangent**) to the circle and extend the lines until they intersect. Now tell them to use the **Intersection Point(s)** tool (⋈) from the Points & Lines menu to plot the intersection point.

Step 2: Direct students to use the **Length** tool (📏) to measure the distance from this intersection point to the two points of tangency. (After selecting the tool, you must click on each endpoint of a segment to find its length.) Then have them grab the circle and move the cursor to change the size. Have them record their findings on their worksheet. (Students should find that the lengths of the tangent segments remain equal.)

Step 3: On page 1.3, two chords are drawn in a circle. Their lengths have already been measured and stored as variables as shown.

Step 4: Have students move to page 1.4 and set up the spreadsheet to automatically capture each length. In the gray formula cell in Column A, they should select **MENU > Data > Data Capture > Automated Data Capture** and enter *w* as the variable to be captured. (The “1” that follows each variable indicates that the data is being captured *automatically*, rather than manually.)

When prompted, have them choose *variable reference* (instead of *column reference*) to capture the values of the variables. Otherwise, the device looks for values in Column W.

Repeat the capture for Columns B, C, and D and variables *x*, *y*, and *z*, respectively.

If desired, students can name each list at the top of the column, such as *wlist*, *xlist*, etc.

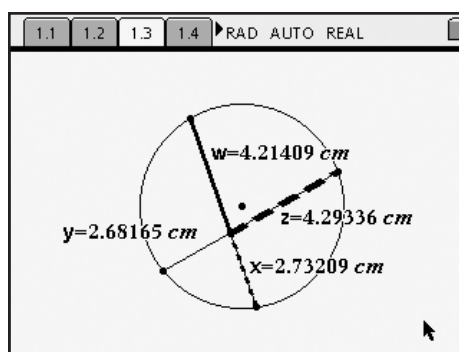
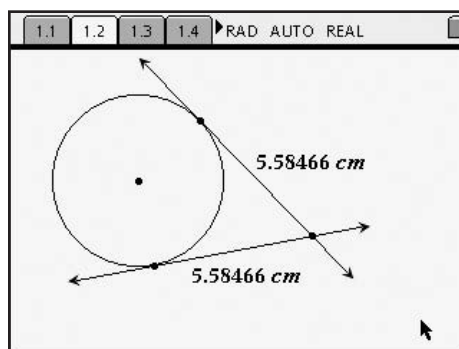
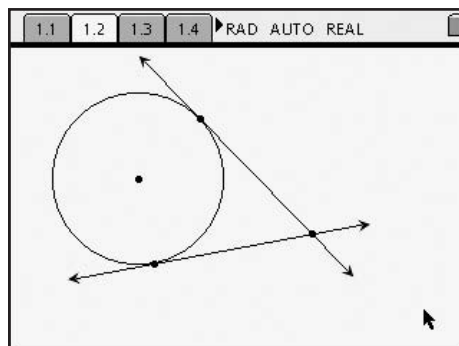

	A	B	C	D	E	F	G
	=captu	=captu	=captu	=captu			
1	4.21...	2.73...	2.68...	4.29...			
2							
3							
4							
5							
6							
	D =capture('z,1)						

Step 5: Tell students to enter formulas into the gray cells of Columns E and F to find the products of the measures of the segments of each chord, that is, $w \cdot x$ and $y \cdot z$. To find the product of the contents in Column A with the corresponding value in Column B, enter $=a[]*b[]$. (Note: If students named the lists, they can use the column names. For example, they may write $=wlist*xlist$.)

Insert the brackets by pressing $\text{ctrl} + \text{[}$ (the left parenthesis). The right bracket automatically appears when the button is pressed. Students may make a particular column wider by selecting **MENU > Actions > Resize**.

Step 6: Have students return to page 1.3 and slowly change the size of the circle. The new lengths are “captured” and recorded in the spreadsheet as they do this. Instruct them to return to the spreadsheet and look at the data in Columns E and F to make a conjecture. (When two chords intersect, the products of the lengths of the segments of each chord are equal.)

	A	B	C	D	E	F
1	.21...	2.73...	2.68...	4.29...	11.5133	11.5133
2						
3						
4						
5						
6						

	A	B	C	D	E	F
1	.21...	2.73...	2.68...	4.29...	11.5133	11.5133
2	.12...	2.67...	2.62...	4.19...	11.008	11.008
3	.79...	2.46...	2.416	3.86...	9.34521	9.34521
4	.67...	2.38...	2.34...	3.74...	8.77563	8.77563
5	.37...	2.18...	2.14...	3.43...	7.38844	7.38844
6						

Problem 2 – Intersecting secants and tangents

Step 1: Instruct students to draw a circle on page 2.1. Then have them use the **Line** tool (—) and the **Tangent** tool (↗) to draw a secant and tangent that intersect outside the circle. Once again, students should plot the point of intersection using the **Intersection Point(s)** tool. (All three of these tools are available from the Points & Lines menu.)

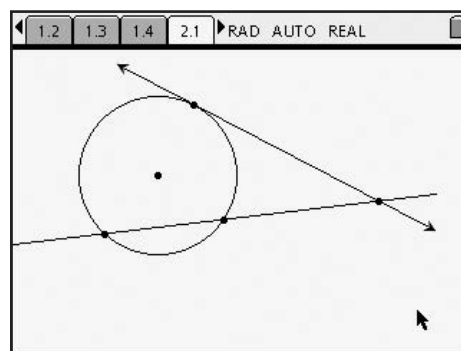

Step 2: Have students again use the **Length** tool to measure the length of the tangent segment and the external and internal secant segments. Store each value as a variable (use t for the tangent segment, se for the external secant segment and si for the internal secant segment) by doing the following: click once on a value to select it, press $\text{ctrl} + \text{stop var}$, enter the variable name, and press enter . Remind students to press esc to deselect each value before attempting to store another.

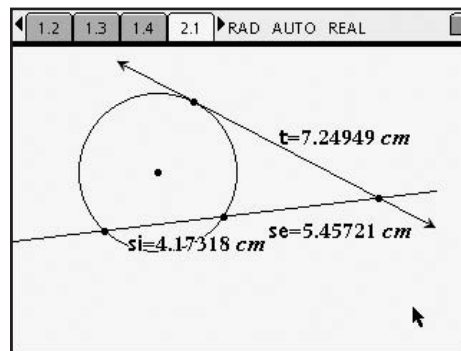

Have them conjecture the relationship between the different segment lengths before continuing.

Step 3: Help students set up the spreadsheet on page 2.2 to manually capture each length. For Column A, have them select **MENU > Data > Data Capture > Manual Data Capture** and enter t as the variable to be captured. (A “0” now follows each variable, indicating that the data will be captured manually.)

Repeat the capture for Columns B and C and variables se and si , respectively. Notice that the current values have not been filled in yet. They will need to be collected manually.

	A	B	C	D	E	F	G
Formula Bar	=capture(=capture(=capture(
1							
2							
3							
4							
5							
6							

Formula Bar: $C | =capture(si,0)$

Step 4: In Columns D and E, have students enter formulas to find the square of the tangent segment and the product of the *entire* secant segment and the external secant segment. Again, students may wish to **Resize** these two columns.

	A	B	C	D	E
Formula Bar	=capture(=capture(=capture(=a[]^2)=(b[]+c[])*b[]				
1					
2					
3					
4					
5					
6					

Formula Bar: $E | = (b[] + c[]) \cdot b[]$

Step 5: Returning to page 2.1, tell students that they must press $\text{ctrl} + \text{.}$ each time they wish to capture specific data values. Have them press $\text{ctrl} + \text{.}$ once and look at the spreadsheet to verify that those values have been captured. Then have them change the size of the circle (capturing at least five different data values), refer to the calculations using the captured data (collected in Columns D and E), and record their findings on the worksheet. Ask why this theorem is often called: “outside squared = outside \times whole.”

	A	B	C	D	E
Formula Bar	=capture(=capture(=capture(=a[]^2)=(b[]+c[])*b[]				
1	7.24...	5.45...	4.17...	52.5551	52.5551
2	4.13...	3.11...	2.37...	17.0852	17.0852
3	5.93...	4.47...	3.41...	35.2793	35.2793
4	8.26...	6.22...	4.76...	68.3753	68.3753
5	9.54...	7.18...	5.49...	91.1613	91.1613
6

Formula Bar: $E | = (b[] + c[]) \cdot b[]$

Step 6: Page 2.3 displays a diagram that shows how the segment lengths are related to the sides of rectangles. If time permits, have students study the picture and drag the circle, discussing how the theorem is related to the areas of the rectangles.

Selecting **Hide/Show** from the **Tools** menu will show how the rectangles were constructed, thereby helping students to see that the width of the bottom rectangle equals the length of the external secant while the top rectangle is actually a square. You can also move the circle and see that the area of the rectangle is always equal to that of the square.

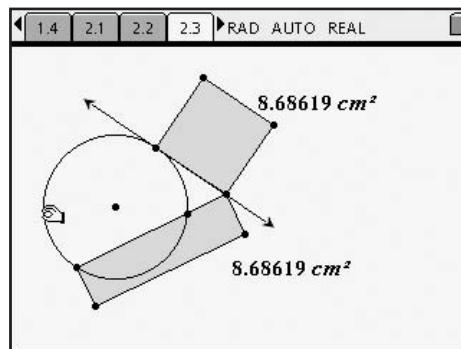

Step 7: On page 2.4, instruct students to draw a circle, two secants that intersect outside the circle, and their point of intersection. Have them measure the **Length** of each of the four secant segments and **Store** them as variables. (Note that they cannot use the variables *se* or *si* because those were already used in Problem 2. Suggest students use *w*, *x*, *y*, and *z*.) Walk around the room to assist students as they do this on their own.

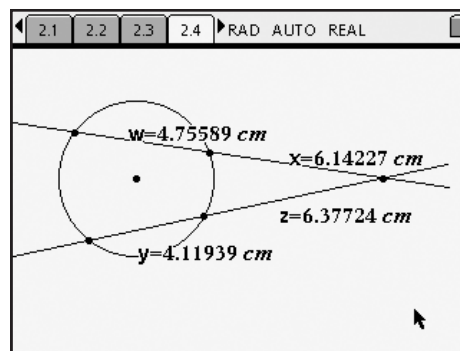

Step 8: Instruct students to use the spreadsheet on page 2.5 to prove that the product of the lengths of one entire secant segment and its external secant segment is equal to the product of the lengths of the other entire secant segment and its external secant segment. Students should capture (either automated or manual) the values of *w*–*z* in Columns A–D, respectively, and set up the formulas in Columns E and F as shown. Assist them as needed. Share that this theorem is often referred to as: “outside × whole = outside × whole.”

	C	D	E	F
1	4.11...	6.37...	66.9394	66.9394
2	1.22...	1.89...	5.89967	5.89967
3	2.38...	3.69...	22.4279	22.4279
4	3.08...	4.77...	37.5559	37.5559
5	4.25...	6.58...	71.3011	71.3011
6	$F = d \cdot (c + d)$			

Step 9: In the above problem, students had choices in which lengths to measure. Instead of the way shown here, they could have found the lengths of the two external secant segments and the lengths of the entire secant segments. As in the previous problem, rectangles with the dimensions of *whole secant segment* by *external secant segment* have the same areas. Students who finish early can be challenged to construct those rectangles.

Problem 3 – Extension

On page 3.2, students are asked to construct a circle, a radius, and a tangent to the circle such that the point of tangency is the intersection of the radius and circle. Have them measure the angle that is formed by selecting **MENU > Measurement > Angle** (they may need to change their settings to *Degree* mode: **CTRL+MENU > File > Document Settings**). Have students grab the point of tangency and move it around the circle. They should find that the angle always remains a right angle.

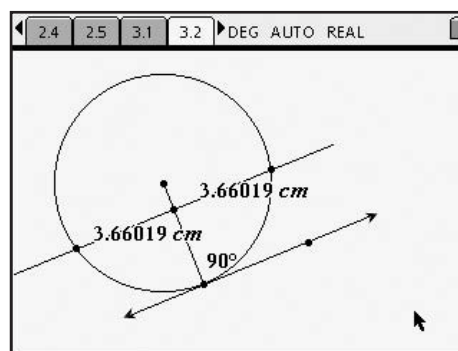

Next, have students construct a perpendicular to the radius, using the **Perpendicular** tool (⊥) from the Construction menu. Have them plot the points of intersection of this line with the circle and then measure the lengths of each segment of the chord that is formed. Students should find these lengths to be equal, even as the line is moved across the length of the radius!

Segments in Circles – ID: 8107

(Student)TI-Nspire File: *GeoAct1_SegmentsInCircles_EN.tns*

1.1 1.2 1.3 1.4 ▸ RAD AUTO REAL

SEGMENTS IN CIRCLES

Geometry
Secants, tangents,
and chords

1.1 1.2 1.3 1.4 ▸ RAD AUTO REAL

1.1 1.2 1.3 1.4 ▸ RAD AUTO REAL

1.1 1.2 1.3 1.4 ▸ RAD AUTO REAL

	A	B	C	D	E	F	G
1							
2							
3							
4							
5							
6							

AI |

1.2 1.3 1.4 2.1 ▸ RAD AUTO REAL

1.3 1.4 2.1 2.2 ▸ RAD AUTO REAL

	A	B	C	D	E	F	G
1							
2							
3							
4							
5							
6							

AI |

1.4 2.1 2.2 2.3 ▸ RAD AUTO REAL

2.1 2.2 2.3 2.4 ▸ RAD AUTO REAL

2.2 2.3 2.4 2.5 ▸ RAD AUTO REAL

	A	B	C	D	E	F	G
1							
2							
3							
4							
5							
6							

AI |

2.3 2.4 2.5 3.1 ▸ RAD AUTO REAL

Extension

On the next page, construct a circle, its radius, and a tangent to the circle such that the point of tangency is the intersection of the radius and circle. Find the measure of the angle that is formed. Move the point of tangency. What do you notice?

2.4 2.5 3.1 3.2 ▸ RAD AUTO REAL

2.5 3.1 3.2 3.3 ▸ RAD AUTO REAL

Go back to page 3.2 and construct a perpendicular line to the radius. Plot the points of intersection of the perpendicular with the circle. Find the lengths of each segment of the chord. Grab and drag the perpendicular across the length of the radius. What do you notice?

How Fast is the U.S. Population Growing?

ID: 8108

Time required

45 minutes

Activity Overview

Students are introduced to modeling exponential data through an investigation of the population of the United States. Students use multiple representations to explore aspects of the growing population. Data was found from the U.S. Census Bureau. The dates run from 1860 to 2006.

Concepts

- Data representation and interpretation
- Visual transformations of exponential functions
- Exponential regressions

Teacher Preparation

This investigation offers opportunities for review and consolidation of key concepts related to exponential, quadratic, cubic, and logarithmic functions. As such, care should be taken to provide ample time for ALL students to engage actively with the requirements of the task, allowing some who may have missed aspects of earlier work the opportunity to build a new and deeper understanding.

- At the Algebra 2/Precalculus level, this activity can serve to consolidate earlier work on exponential functions. It offers a suitable introduction to exploring exponential data, model fitting using exponential functions, and interpretation of graphs.
- Begin by reviewing with students the general exponential form of $y = ab^x$.
- The screenshots on pages 38–40 demonstrate expected student results. Refer to the screenshots on page 41 for a preview of the student .tns file.
- **To download the .tns file and student worksheet, go to <http://education.ti.com/exchange> and enter “8108” in the search box.**

Classroom Management

- This activity is intended to be **teacher-led** with students in **small groups**. You should seat your students in pairs so they can work cooperatively on their handhelds. You may use the following pages to present the material to the class and encourage discussion. Students will follow along using their handhelds, although the majority of the ideas and concepts are only presented in **this** document; be sure to cover all the material necessary for students’ total comprehension.
- The student worksheet is intended as an investigation through the main ideas of the activity. It also serves as a place for students to record their answers. Alternatively, you may wish to have the class record their answers on a separate sheet of paper, or just use the questions posed to engage a class discussion.
- Suggestions for optional extension questions are provided at the end of this activity.

TI-Nspire™ Applications

Calculator, Graphs & Geometry, Lists & Spreadsheet, Notes

This investigation explores the growth rate of the United States population from 1860 through 2006. The years have been modified so that “0” represents the year 1800. Throughout the activity, students will develop exponential models to make conjectures based on interpolation and extrapolation of the data.

Step 1: Students should first study the data in the spreadsheet on page 1.3 and record any observations on their worksheets. Encourage them to discuss their impressions and observations of the data. You may want to pose questions about what type of function would best model the data.

A	year	B	uspop	C	D	E
1	60		31443000			
2	70		38558000			
3	80		50155783			
4	90		62622250			
5	100		76212168			

Step 2: On page 1.4, students find a *Graphs & Geometry* application with an appropriate window for this data and pre-constructed sliders at the top of the page. Instruct students to create a scatter plot of the data by selecting **MENU > Graph Type > Scatter Plot**. The function entry line appears and students should press enter to open the drop-down menu for the x-variable—select **year**. Press tab to move to the drop-down menu for the y-variable—select **uspop**.

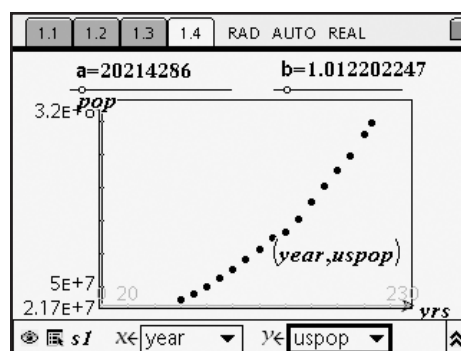

Step 3: Tell students to select the **Point On** tool (---) from the Points & Lines menu and click on a data point—this will allow them to trace the data. Select **MENU > Tools > Attributes** to change the appearance of that point to be an open circle (to increase its visibility). If the y-coordinate appears in scientific notation, instruct the students to hover the cursor over it and press the enter key to display the number in standard notation.

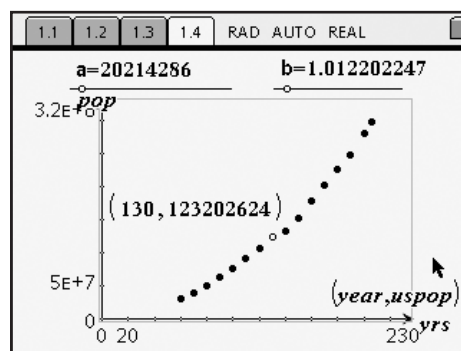

Step 4: Direct students to press $\text{ctrl} + \text{G}$ to unhide the function entry line. They should then select **MENU > Graph Type > Function** to change graphing modes, key in “ $a \cdot b^x$ ” for **f1**, and press enter . (Note: It is important that students enter the multiplication symbol between the pre-defined variables a and b . Otherwise, the device searches for the variable named “ ab .”)

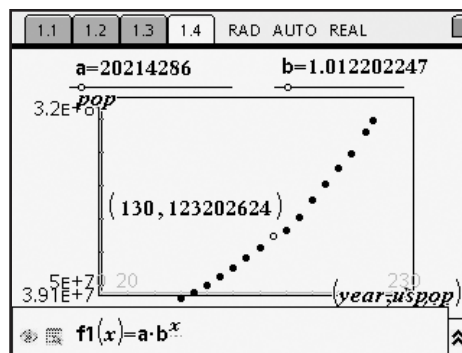

Step 5: The graph of the function and the function rule now appear on the screen. Suggest that students press $\text{ctrl} + \text{G}$ once again to *hide* the function entry line. They may also grab and drag text boxes and rearrange the screen so as to provide more organization and better visibility.

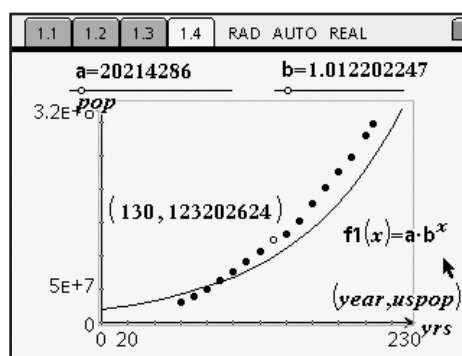

Step 6: Instruct students to grab and drag the points on the a and b sliders until they have a visually “good fit” of the data. One sample equation is given by:

$$f1(x) = 20,026,786 \cdot 1.013280899^x$$

This would be a good opportunity to discuss why they choose the values they did to get the fit they have.

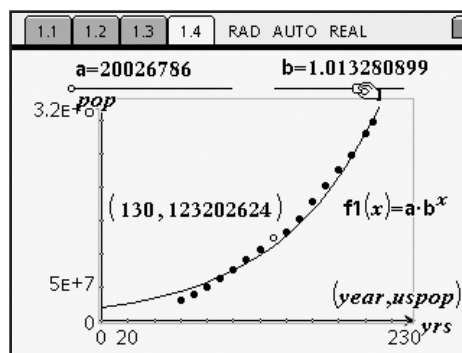

Step 7: Tell students to once more use the **Point On** tool—this time placing a point on the function. Again, students may wish to use the **Attributes** tool to change the point's appearance and press the $\left[\text{Ⓢ} \right]$ key while hovering over the point's coordinates to adjust the display digits.

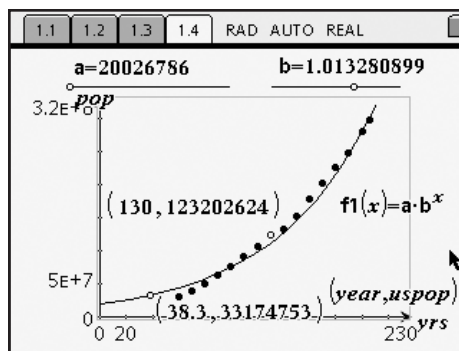

Step 8: Next, have students insert a new page by pressing $\left[\text{ctrl} \right] + \left[\text{1} \right]$ and selecting **Add Calculator**. Students should be directed to perform an exponential regression by selecting **MENU > Statistics > Stat Calculations > Exponential Regression**.

To set up the regression, tell them to select **year** as the X List and **uspop** as the Y List. (Press $\left[\text{tab} \right]$ to move between the drop-down menus.) Make sure the regression equation is set to be saved as **f2** and press $\left[\text{enter} \right]$ to compute the regression.

"Title"	"Exponential Regression"
"RegEqn"	"a*b^x"
"a"	1.57663E7
"b"	1.01497
"r^2"	.979461
"r"	.989677
"Resid"	"{...}"
"ResidType"	"{...}"

Step 9: Now students should return to page 1.4, unhide the function entry line ($\left[\text{ctrl} \right] + \left[\text{G} \right]$) and press \blacktriangle on the NavPad to access **f2** if needed. Tell them to press $\left[\text{enter} \right]$ to display its graph, and change its **Attributes** so it appears as a dashed line. Now direct them to repeat Step 7 above: placing a point on this function, thus enabling it to be traced, altering its attributes and coordinates as desired.

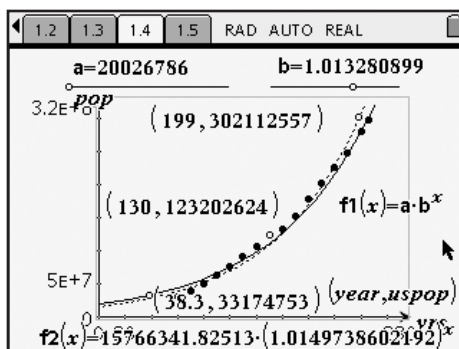

Students now have the information they need to explore the U.S. population! Have them complete the exercises on the student worksheet, or use those questions to foster a whole-class discussion.

Solutions – Student Worksheet Exercises

- Answers will vary. Accept reasonable explanations.
- $\approx 1.5\%$; Possible answer: In exponential equations of the form $y = a(1 + b)^x$, b represents the percent of increase. In the regression equation, $1 + b \approx 1.015$, so $b \approx 0.015$, or 1.5%.
- a = population of the U.S. in 1800; Answers will vary. Accept reasonable explanations.
- population in 2020 $\rightarrow x = 220$; $f_2(220) \approx 414,762,602$;
Accept reasonable predictions for f_1 .
- population in 1776 $\rightarrow x = -24$; $f_2(-24) \approx 11,036,068$;
Accept reasonable estimates for f_1 .

Optional Extension Questions

- Use residuals and \sum^2 to compare the two models.
- Use other types of functions to model the data.
- Gather data for the populations of India or China and compare initial values and growth rates with that of the U.S.
- Compare population versus land mass.

How Fast is the U.S. Population Growing? – ID: 8108

(Student)TI-Nspire File: Alg2Act1_USPopulation_EN.tns

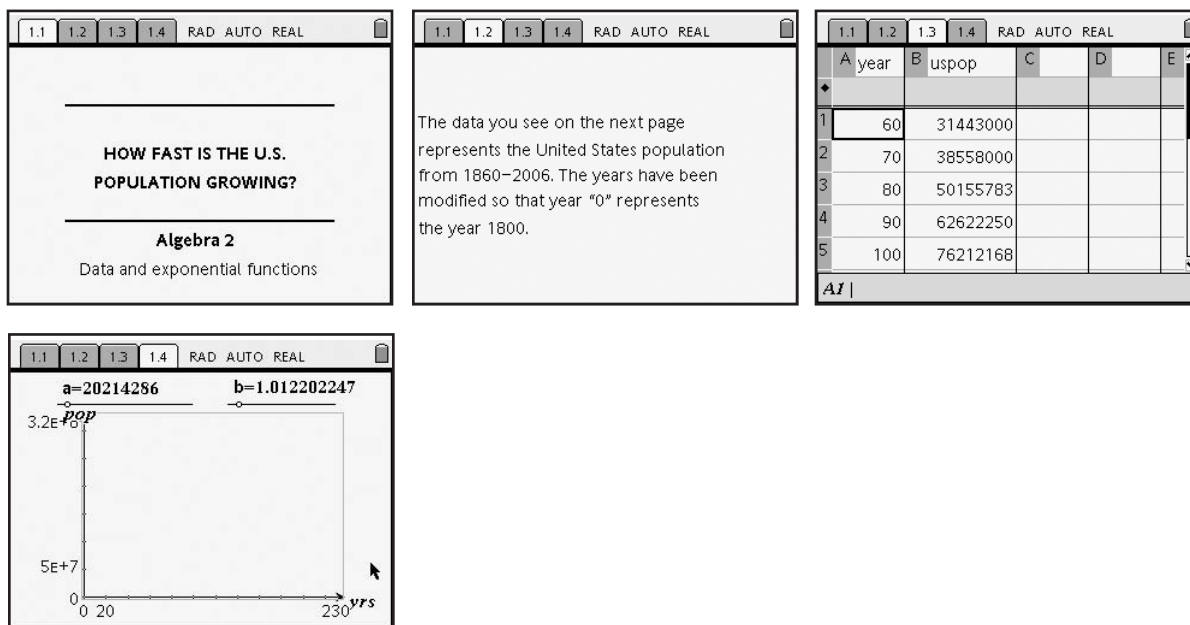

Finding Extraneous Solutions

ID: 8109

Time required

45 minutes

Activity Overview

Students will solve different types of equations step-by-step graphically. They will discover that some of the equations have an extraneous solution and they will investigate at which step in solving the equation that these “extra” solutions appear.

Concepts

- Solving equations graphically
 - Solving equations algebraically
-

Teacher Preparation

This investigation offers an extension after students have learned how to solve equations, or may serve as an introduction to solving more difficult equations.

- This activity could be used in Algebra 2 as an extension after students have solved different types of equations. This activity could also be used in Precalculus as review of the different types of equations that students solved in Algebra 2.
- Begin by reviewing with students how to solve equations graphically by treating each side of an equation as a separate function—the solution to the equation is the functions’ point of intersection.
- The screenshots on pages 44–47 demonstrate expected student results. Refer to the screenshots on page 48 for a preview of the student .tns file.
- **To download the .tns file and student worksheet, go to <http://education.ti.com/exchange> and enter “8109” in the search box.**

Classroom Management

- This activity is intended to be **teacher-led**. You may use the following pages to present the material to the class and encourage discussion. Students will follow along using their handhelds, although the majority of the ideas and concepts are only presented in **this** document; be sure to cover all the material necessary for students’ total comprehension.
- The student worksheet is intended to guide students through the main ideas of the activity, while providing more detailed instruction on how they are to perform specific actions using the tools of the TI-Nspire handhelds. It also serves as a place for students to record their answers. Alternatively, you may wish to have the class record their answers on a separate sheet of paper, or just use the questions posed to engage a class discussion.
- Information for an optional extension is provided at the end of this activity; information for students is provided on the student worksheet and in Problem 3 of the student TI-Nspire file. Should you not wish students to complete the extension, you may delete Problem 3 of the .tns file and have students disregard that portion of the student worksheet.

TI-Nspire™ Applications

Calculator, Graphs & Geometry, Lists & Spreadsheet, Notes

Problem 1 – Solving a quadratic equation

Students will work through the solving of the equation $2x^2 + 3 = 5x$ graphically and step-by-step. They simply need to change the equations in **f1(x)** and **f2(x)** to represent the left- and right-hand sides, respectively, of the equation in each step. The functions can be altered by double-clicking in the text box on the *Graphs & Geometry* page. Students will find that the x-coordinates of the intersection points remain the same each time the equation is manipulated graphically.

Solve graphically: $2x^2 + 3 = 5x$

Step 1: $2x^2 + 3 = 5x$
 Step 2: $2x^2 - 5x + 3 = 0$
 Step 3: $(2x - 3)(x - 1) = 0$
 Step 4: $x = \frac{3}{2}$ and $x = -1$

You may wish to work through this first problem with students if they are unfamiliar with solving equations graphically. Students will be moving back and forth between pages 1.3 and 1.4 to access the equations and then the graph. Encourage them to write the solution(s)—i.e., the x-coordinates of the point(s) of intersection of functions **f1** and **f2**—on their worksheet.

The graphs of the functions at each step in the solution are shown at right and below.

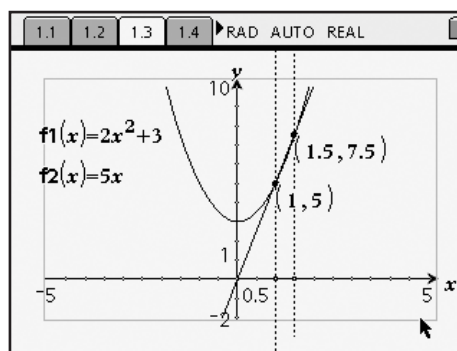

Step 1

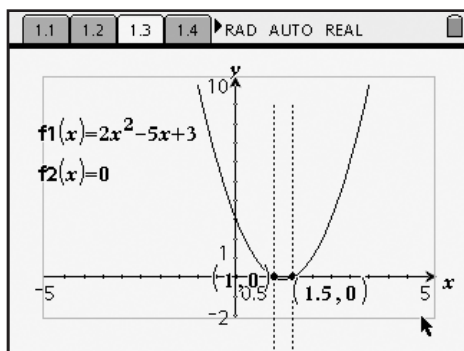

Step 2

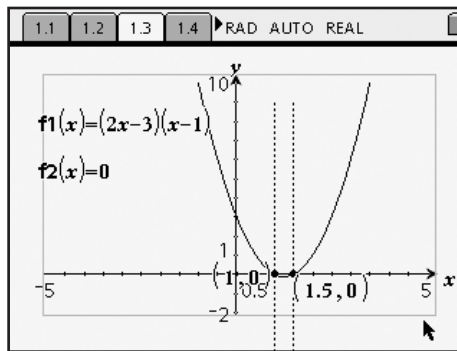

Step 3

On page 1.5, students can check their solutions algebraically and by using a table of values. To use the table, they will need to return to the *Graphs & Geometry* page and re-enter the Step 1 equations as $f1(x)$ and $f2(x)$. For the *Calculator* application, the first solution is checked for them—entering “ $f1(1)=f2(1)$ ” returns **true**. Have students check the second solution, 1.5, by entering “ $f1(1.5)=f2(1.5)$ ” and pressing $\frac{\square}{\text{enter}}$. If the result is **true**, then the value is, in fact, a solution.

x	f1(x): 2*x^2+...	f2(x): 5*x	f1=f2
.5	3.5	2.5	false
1.	5.	5.	true
1.5	7.5	7.5	true
7.5	27.5	37.5	false

Students should conclude that $x = 1$ and $x = 1.5$ are both solutions to the equation $2x^2 + 3 = 5x$.

Problem 2 – Solving a radical equation

In Problem 2, students will approach the equation $\sqrt{x + 11} + 1 = x$ in the same manner, but this time they will observe the appearance of an extraneous solution during the graphing of the functions in Step 3.

Solve graphically: $\sqrt{x + 11} + 1 = x$

Step 1: $\sqrt{x + 11} + 1 = x$

Step 2: $\sqrt{x + 11} = x - 1$

Step 3: $x + 11 = (x - 1)^2$

Step 4: $x + 11 = x^2 - 2x + 1$

Step 5: $0 = x^2 - 3x - 10$

Step 6: $0 = (x - 5)(x + 2)$

Step 7: $x = 5$ and $x = -2$

Again, the graphs of the functions at each step in the solution are shown below and on the following page.

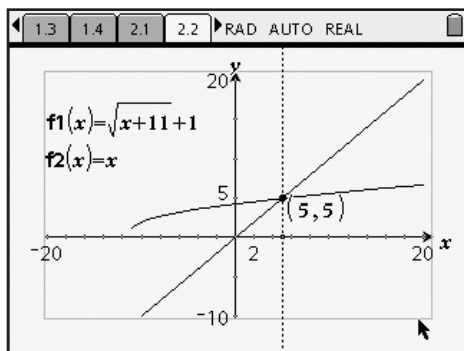

Step 1

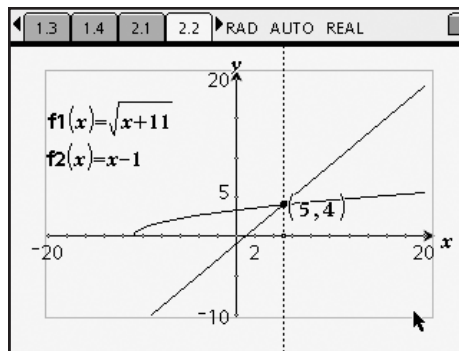

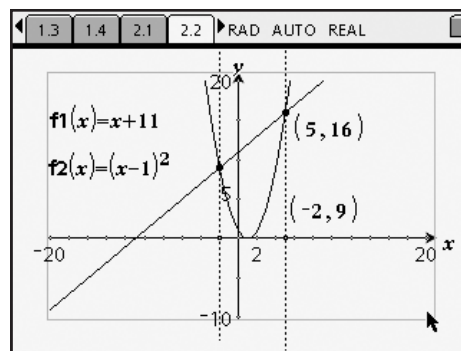

Step 2

When they have graphed the equations in Step 3, students may wish to adjust the window. To accomplish this, one option is to simply grab a tick mark on the positive y -axis and drag it down towards the origin. Another way is to select **MENU > Window > Window Settings** and enter the desired values.



Step 3

Students may have to plot the new intersection for the new solution by selecting **MENU > Points & Lines > Intersection Point(s)** and then clicking once on the graph of each function. They may also wish to construct a perpendicular (using the **Perpendicular** tool () from the Construction menu) to the x -axis through this new point. Using the **Attributes** tool () from the Tools menu, students can change the appearance of the line.

In graphing the equations for Step 4, students should observe that the graph of the function $y = (x - 1)^2$ did not change position as it was altered to the function $y = x^2 - 2x + 1$. Ask students to explain why this happened. (The expressions $(x - 1)^2$ and $x^2 - 2x + 1$ are equivalent—the former is merely the factored form of the latter. Thus, their graphs are identical.)

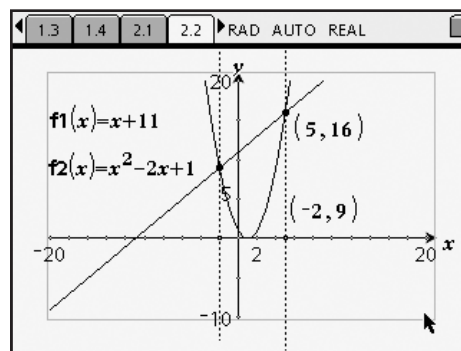

Step 4

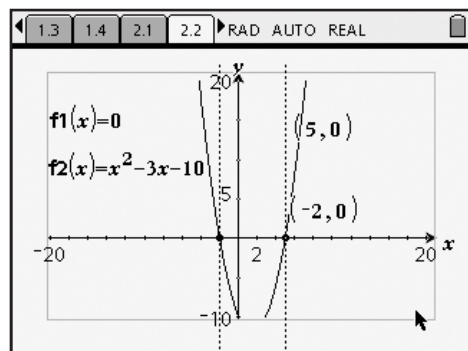

Step 5

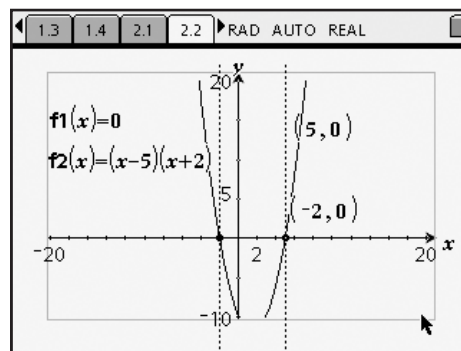

Step 6

Students should once again check their solutions—remind them to reset the functions **f1** and **f2** to be as they were in Step 1. This time, students should find that only *one* of their solutions, $x = 5$, makes the equation true. Tell them that $x = -2$ is called an “extra” or *extraneous* solution.

$f1(x)=f2(x)$	x	f1(x):...	f2(x):...
true		$\sqrt{(x+1)}$	x
	3.	4.74166	3
	4.	4.87298	4
	5.	5.	5

Extension – Solving a rational equation

As an optional extension, Problem 3 provides students with a step-by-step solution to a rational equation. A *Graphs & Geometry* page is provided, for the students to use as before. Have them identify the step in which the extraneous solution appeared. A function table is also provided for students to verify whether the solutions are “true” solutions or extraneous ones. ($x = -3$ is a true solution; $x = 3$ is an extraneous solution—both expressions are undefined for $x = 3$.)

Solve graphically: $\frac{3x}{x-3} = \frac{2x+3}{x-3}$

Step 1: $\frac{3x}{x-3} = \frac{2x+3}{x-3}$

Step 2: $(3x)(x-3) = (2x+3)(x-3)$

Step 3: $3x^2 - 9x = 2x^2 - 9x + 9$

Step 4: $x^2 = 9$

Step 5: $x = -3$ and $x = 3$

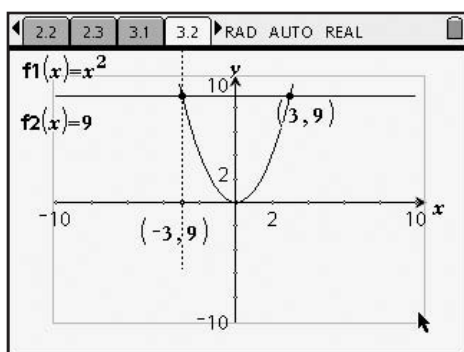

x	f1(x):...	f2(x):...
	$\frac{3*x}{(x-3)}$	$\frac{(2*x+3)}{(x-3)}$
1.	-1.5	.5
2.	-6.	-1.
3.	#UNDEF	#UNDEF
4.	12.	5.

Finding Extraneous Solutions – ID: 8109

(Student)TI-Nspire File: *PreCalcAct1_ExtraneousSolutions_EN.tns*

1.1 1.2 1.3 1.4 ▸ RAD AUTO REAL

FINDING EXTRANEOUS SOLUTIONS

Precalculus

Solving equations graphically and algebraically

1.1 1.2 1.3 1.4 ▸ RAD AUTO REAL

Solve graphically: $2x^2 + 3 = 5x$

Step 1: $2x^2 + 3 = 5x$
 Step 2: $2x^2 - 5x + 3 = 0$
 Step 3: $(2x - 3)(x - 1) = 0$
 Step 4: $x = \frac{3}{2}$ and $x = 1$

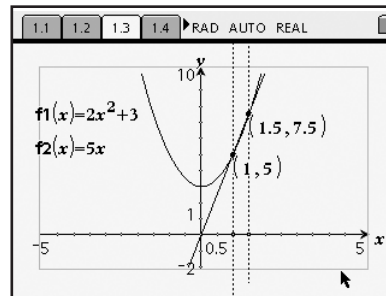

1.1 1.2 1.3 1.4 ▸ RAD AUTO REAL

Check your two solutions algebraically and verify on the table.

x	f1(x)...	f2(x)...	f1 = f2(1)
	$2x^2 + \dots$	$5x$	2^x
0.	3.	0.	true
.5	3.5	2.5	
1.	5.	5.	

3. 1/99

1.2 1.3 1.4 2.1 ▸ RAD AUTO REAL

Solve graphically: $\sqrt{x + 11} + 1 = x$

Step 1: $\sqrt{x + 11} + 1 = x$
 Step 2: $\sqrt{x + 11} = x - 1$
 Step 3: $x + 11 = (x - 1)^2$
 Step 4: $x + 11 = x^2 - 2x + 1$
 Step 5: $0 = x^2 - 3x - 10$
 Step 6: $0 = (x - 5)(x + 2)$
 Step 7: $x = 5$ and $x = -2$

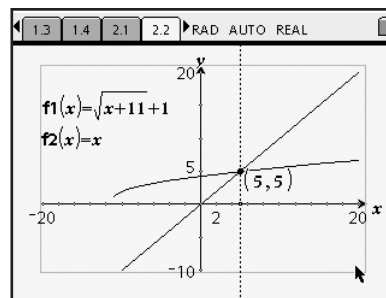

1.4 2.1 2.2 2.3 ▸ RAD AUTO REAL

Check your two solutions algebraically and verify on the table.

x	f1(x)...	f2(x)...
	$\frac{3x}{x-3}$	$\frac{2x+3}{x-3}$
0.	4.31662	1
1.	4.4641	1
2.	4.60555	2

0/99 4.3166247903554

2.1 2.2 2.3 3.1 ▸ RAD AUTO REAL

Solve graphically: $\frac{3x}{x-3} = \frac{2x+3}{x-3}$

Step 1: $\frac{3x}{x-3} = \frac{2x+3}{x-3}$
 Step 2: $(3x)(x-3) = (2x+3)(x-3)$
 Step 3: $3x^2 - 9x = 2x^2 - 9x + 9$
 Step 4: $x^2 = 9$
 Step 5: $x = -3$ and $x = 3$

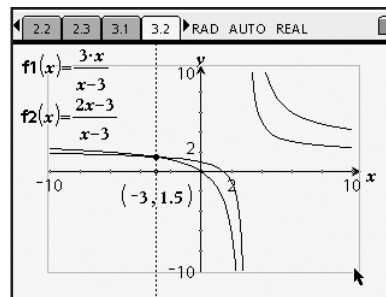

2.3 3.1 3.2 3.3 ▸ RAD AUTO REAL

Check your solutions on the function table.

x	f1(x)...	f2(x)...
	$\frac{3x}{x-3}$	$\frac{2x+3}{x-3}$
-1.	.75	1.25
0.	0.	1.
1.	-1.5	.5
2.	-6.	-1.

0.

Derivative Trace**ID: 8110****Time required**

45 minutes

Activity Overview

Students will look at several functions in which a tangent has been constructed to the curve. By dragging the tangent to the curve, the graph of the derivative will be traced out using the “automatic data capture” feature. Emphasis will be placed on exploring the relationship between the slope of the original curve and the y-value of the graph of the derivative. Students will also discover the relationship between local extrema and the corresponding zeros on the graph of the derivative (assuming the derivative is defined at such points). Additionally, students will see the connection between intervals where a function is increasing and decreasing and the sign of the derivative. Finally, students will look at examples in which the derivative is not defined at a certain point, such as a discontinuity, corner, or vertical tangent.

Concepts

- Slope of a tangent
- Definition of the derivative
- Graph of the derivative

Teacher Preparation

This investigation offers an opportunity for students to develop an understanding of the relationships between the graph of a function and its derivative. The essence of this activity centers on a student’s ability to recognize that the y-coordinate of the derivative at each point on a graph is equal to the slope of the tangent to the graph. The “automatic data capture” feature enables students to see this important characteristic by placing the focus on the graph of the derivative one point at a time, rather than the function as a whole. Furthermore, it is helpful if students participate in this activity before having learned the rules for differentiation (i.e. power rule, product rule, etc.) as knowledge of these rules will allow students to determine the shape of the graph by identifying the function’s derivative analytically.

This activity illustrates the key relationships that exist between the graph of a function and its derivative. Review with students how to find the slope of a tangent at a specific point using limits. For example, students should be familiar with the following forms for finding the

derivative at $x = a$, $\lim_{x \rightarrow a} \frac{f(x) - f(a)}{x - a}$ and $\lim_{h \rightarrow 0} \frac{f(a + h) - f(a)}{h}$.

After working through the examples in this activity, students will start to recognize the following important characteristics:

- While the graph of the derivative of a function was explored one point at a time, each locus of points created in this activity defines the derivative as a function, which can be represented by the formula, $\lim_{h \rightarrow 0} \frac{f(x + h) - f(x)}{h}$.

- As students start thinking of the derivative as a function, they will also notice other characteristics that will allow them to determine the formula for a derivative. For example, students will likely notice that the degree of the derivative of a polynomial function is one less than the degree of the original function. Some students may even recognize that derivatives of polynomial functions of the form $f(x) = a_n x^n + a_{n-1} x^{n-1} + \dots + a_1 x + a_0$ are of the form $f'(x) = n \cdot a_n x^{n-1} + (n-1) a_{n-1} x^{n-2} + \dots + a_1$. These types of observations should be encouraged and will provide a nice lead-in to the power rule.
- The screenshots on pages 51–53 demonstrate expected student results. Refer to the screenshots on page 54 for a preview of the student .tns file.
- **To download the .tns file and student worksheet, go to <http://education.ti.com/exchange> and enter “8110” in the search box.**

Classroom Management

- This activity is designed to be **student-centered** with the teacher acting as a facilitator while students work cooperatively. The student worksheet is intended to guide students through the main ideas of the activity and provide a place to record their observations.
- Students will manipulate pre-made sketches, rather than create their own constructions. Therefore, a basic working knowledge of the TI-Nspire handheld is sufficient.
- After each trace is completed, students should advance to the Lists & Spreadsheet page, position the cursor in the formula cell (gray) for Column A, and press  twice to clear the data. Students should then repeat this process for Column B. If these steps are not followed, there will be too much data, causing the device to run slowly or possibly crash.
- It is also recommended that students move the cursor slowly from the left side of the screen to the right side of the screen only once. This will also limit the amount of data that is accumulated in the Lists & Spreadsheet application.
- The ideas contained in the following pages are intended to provide a framework as to how the activity will progress. Suggestions are also provided to help ensure that the objectives for this activity are met.

TI-Nspire™ Applications

Graphs & Geometry, Lists & Spreadsheet, Notes

One focus question defines this activity: *What type of graph is produced when every x -value of a function is paired with the slope of its corresponding tangent line?* Some discussion should follow this question, including a demonstration of what the question means by referring to the graph on page 1.2. Tell students that the point on the x -axis has coordinates $(a, 0)$, and we will simply refer to the point as “ a .” Ask them to think about the point P , whose x -coordinate is a and whose y -coordinate is the slope of the tangent to the graph at $x = a$. Then ask students if they think they can identify the path that P will trace out as a is moved along the x -axis.

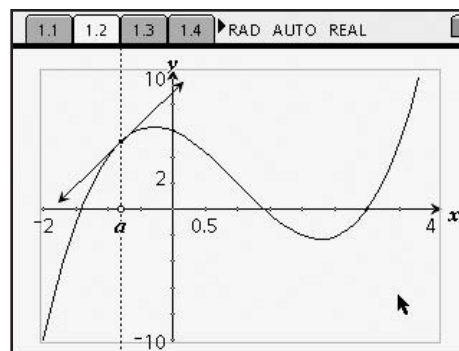

Problem 1 – Investigating the graph of the derivative of polynomial functions

Step 1: Tell students that they will work cooperatively by starting with a study of the graph shown on page 1.3. Students will be asked to explain that point P , located in the “cross-hairs,” represents a point with an x -coordinate equal to a and y -coordinate equal to the slope of the tangent to f at $x = a$. For this and subsequent sketches, the coordinates of point P are given in the top right corner of the screen as a reference for students.

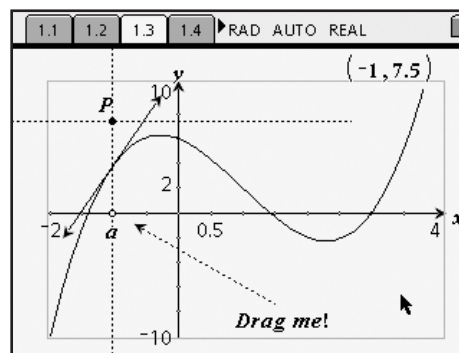

Step 2: Next, students will grab point a and slowly move it along the x -axis. In doing so, the position of point P will move accordingly. Students should now be focusing on the location of point P as point a is dragged. In particular, they should be thinking about point P as having a y -coordinate equal to the slope of the tangent line. They will visualize the complete graph of the derivative in the next step.

Step 3: Students will advance to page 1.4, grab point a , and slowly move it along the x -axis. It is important that students observe that the derivative is positive when f is increasing and negative when f is decreasing. Students will also recognize that local maximum and minimum values of f correspond to x -intercepts of the derivative. Encourage them to realize that this occurs because the tangent to the curve at these points is horizontal.

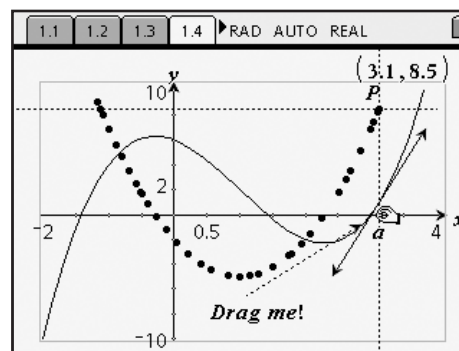

Step 4: Students should now advance to page 1.5 and clear the data contained in Columns A and B. To do so, simply highlight the formula cell (in gray) for each column and press ⏏ twice. This will clear the collected data while retaining the automatic data capture feature.

	A xlist	B ylist
	$=\text{capture}(xval,1)$	$=\text{capture}(\text{slope},1)$
1	3.08029197081	9.0991538586
2		8.25760662635
3		7.71096056095
4		7.1758228339
5		6.9125695972
6		6.9910012774

B | ylist:=capture(slope,1)

Step 5: Students are instructed to go back to page 1.4 and press $\text{⌘} + \text{Ⓔ}$ to reveal the Entry Line. They will enter the function $f(x) = x^4 - 8x^2 + 5$ as **f1**, hide the Entry Line by pressing $\text{⌘} + \text{Ⓔ}$ again, and resize the window to be similar to the one shown in the diagram below.

Step 6: Next, students will drag point *a* and trace out the derivative. They will compare their results with a graph they produced by hand.

Repeat Steps 4–6 with additional polynomials, if you feel that students need more practice.

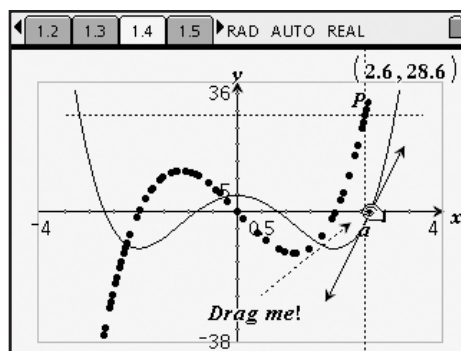

Problems 2 & 3 – Investigating places where the derivative is not defined

Step 1: Students will advance to page 2.1. As before, they will be asked to sketch a graph of the derivative before dragging point *a*. The screen at right shows that the derivative is not defined for values of *x* where there is a “corner.”

Make sure that students clear the data from page 2.2 (see Step 4 above) before advancing to Problem 3.

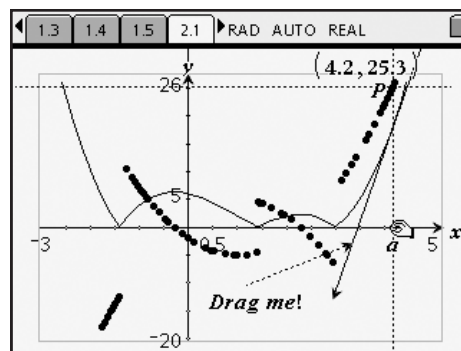

Step 2: In Problem 3, students will notice that the derivative is not defined for values of x in which an infinite discontinuity exists. Students should again clear the collected data after performing this trace.

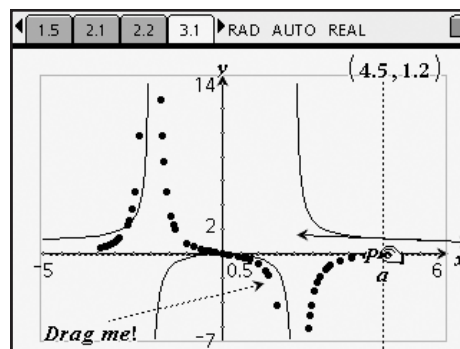

Problems 4 & 5 – Derivatives with interesting characteristics

Step 1: Students will advance to page 4.1. Using what they have learned so far, they will sketch a graph of the derivative and verify their results by dragging point a . They should recognize that the derivative of $y = \sin x$ is $y = \cos x$. Again, students will clear the data before proceeding.

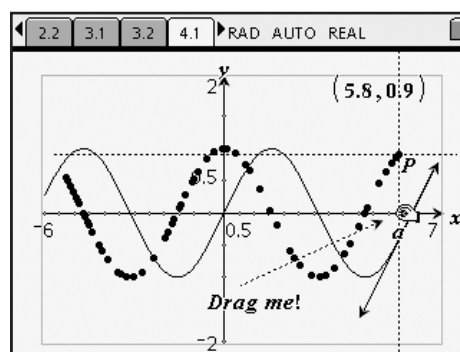

Step 2: Students should advance to page 5.1, where they will again sketch a graph of the derivative and verify their results by dragging point a . Here, they should observe that the derivative of $y = e^x$ is itself.

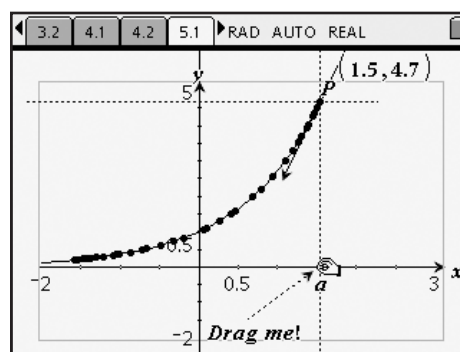

Derivative Trace – ID: 8110

(Student)TI-Nspire File: *CalcAct1_DerivativeTrace_EN.tns*

1.1 1.2 1.3 1.4 RAD AUTO REAL

DERIVATIVE TRACE

Calculus

Tangent lines, derivatives, and
graphs of derivatives

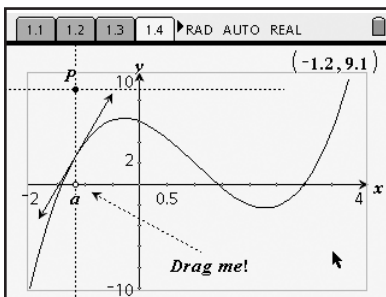
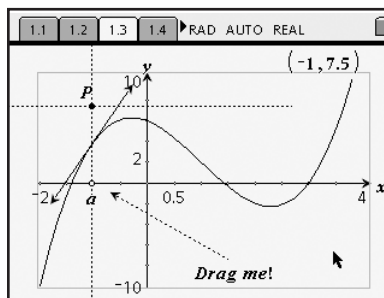
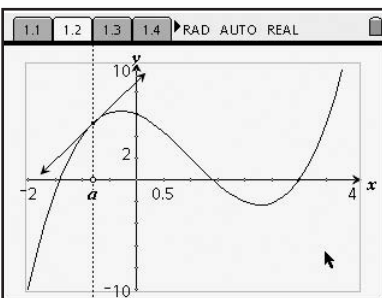

1.2 1.3 1.4 1.5 RAD AUTO REAL

A	xlist	B	ylist	C
◆	=capture(xval,1)	=capture(slope,1)		
1	-1.16788321168	9.0991538586		
2				
3				
4				
5				
6				

A1 | -1.16788321168

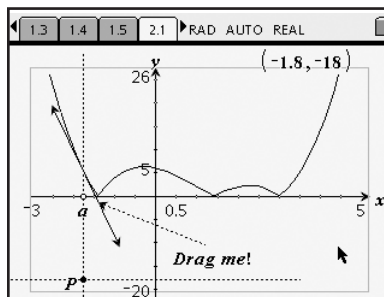

1.4 1.5 2.1 2.2 RAD AUTO REAL

A	xlist1	B	ylist1	C
◆	=capture(xval,1)	=capture(slope,1)		
1	-1.76923076923	-18.0059181595		
2				
3				
4				
5				
6				

A1 |

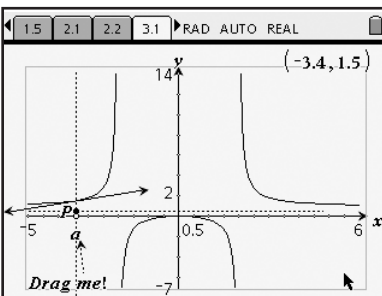

2.1 2.2 3.1 3.2 RAD AUTO REAL

A	xlist1	B	ylist1	C
◆	=capture(xval,1)	=capture(slope,1)		
1	-4.24	.1736163914		
2				
3				
4				
5				
6				

A1 | -4.24

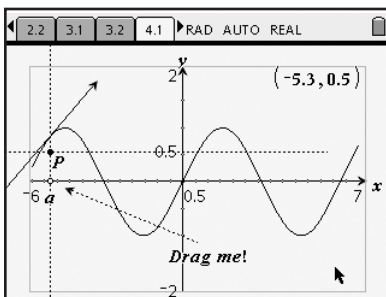

3.1 3.2 4.1 4.2 RAD AUTO REAL

A	xlist1	B	ylist1	C	D
◆	=capture(xval,1)	=capture(slope,1)			
1	-5.280442804...	.53799245071			
2					
3					
4					
5					
6					

A1 | -5.28044280443

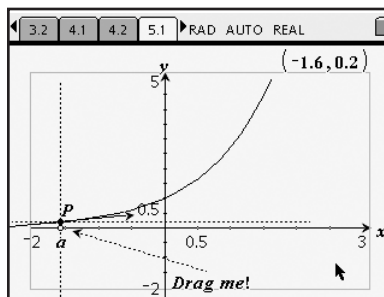

4.1 4.2 5.1 5.2 RAD AUTO REAL

A	xlist1	B	ylist1	C	D	E
◆	=capture(xval,1)	=capture(slope,1)				
1	-1.580291...	.20591500...				
2						
3						
4						
5						
6						

TI-*n*spire™

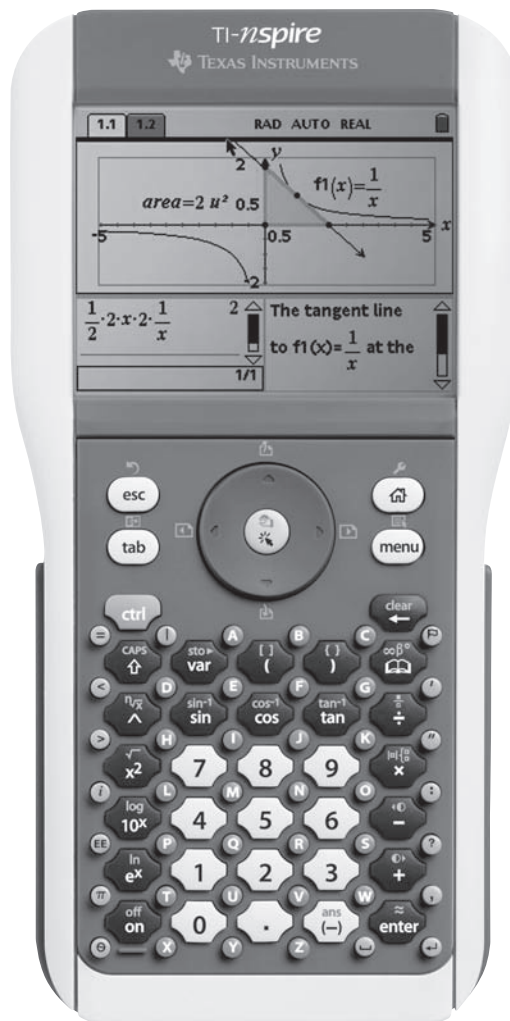

APPENDIX

TI-*nspire*[™] Learning Handheld Quick Reference

NavPad
press in any direction to move the cursor

Click button
press to select items on the screen
press **ctrl** + or press and hold to "grab" objects

Shortcuts

- ctrl** + **esc** undo; + **esc** redo
- ctrl** + provides tools to manage and edit your document
- ctrl** + **menu** provides options available to current application
- esc** closes menus and dialog boxes
- tab** moves to the next field in a dialog or between fields in an expression template
- allows you to add applications, manage documents, or view system information
- menu** opens the application menu for working with the current application
- ctrl** alternates between primary and secondary functions on keyboard
- applies language-specific accents or punctuation to international characters

Moving around in documents

- ctrl** + displays next page
press in any direction
- ctrl** + **tab** moves to next application in a split layout
- tab** moves between fields within the application

Managing Files and Folders

- 6** opens My Documents
- ctrl** **N** opens a new document
- ctrl** **I** inserts a new page

Navigation

- ctrl** + from page, displays Page Sorter
from Page Sorter, displays My Documents
- ctrl** + from My Documents, displays Page Sorter
from Page Sorter, displays page
- ctrl** + **7** Home
- ctrl** + **1** End
- ctrl** + **9** Page Up
- ctrl** + **3** Page Down

Changing Mode Settings

- 8** **1** Current document settings
- 8** **2** System settings

Entering Math Expressions

- opens catalog
- ctrl** + opens symbol palette
- ctrl** + opens math templates

Quick Reference Card

Opening a document

1. Press to open My Documents.
2. Press or to highlight the folder that contains the document.
3. Press to expand the folder.
4. Press or to highlight the document you want to open.
5. Press or the click button to open the document.

Creating a new document

Press or to open a new document.

Creating a split-page layout

1. Press to view the standard layouts.
2. Press the number of the layout to apply it to the page.

-OR-

1. Press to apply a custom split to a layout.
2. Use arrow keys to move the splitter bar.
3. Press to select a layout.

Adding a problem to a document

Press .

A new problem with one page is added.

Adding a page to a problem

Press or to add a blank page.

A new page is added to the current problem.

-OR-

Press and then select an application. A new page with that application is added.

Saving a document

To save your document, press or press .

Using the Page Sorter

1. From the document view, press .
2. Press , , , or to highlight the page or problem you want to move.
3. Press and hold the click button until the "grab" hand displays on the screen.
4. Drag the page to the desired location and drop it in place.

Using the catalog

1. From the document view, press to open the catalog.
2. Press to highlight the tabs, then press , , , or to move to the tab that contains the function, symbol or expression you want to insert into your problem.
3. Press until the item you want to insert is highlighted.
4. Press to insert the item.



**Your Passion.
Our Technology.
Student Success.**

TI-Nspire™, TI-89 Titanium™, and TI Connect™ are trademarks of Texas Instruments.
All other trademarks are the property of their respective owners.

©2007 Texas Instruments

NS/SB/1L1/A