



# Unpacking the TI-Innovator™ Breadboard Pack

TI PROFESSIONAL DEVELOPMENT

## Activity Overview

This activity allows participants to identify the parts and pieces that come in the I/O accessories kit.

Match the items in the word bank with the items in the TI-Innovator Box: place the number next to the item.



(1) Breadboard	(12) SPDT Slide Switch
(2) Green LED	(13) Infrared Transmitter
(3) Thermistor	(14) TI Analog Temperature Sensor
(4) Red LED	(15) Visible Light Sensor
(5) Diode	(16) 4-AA Battery Holder
(6) TTL Power MOSFET	(17) Potentiometer with Knob
(7) Small DC Motor	(18) RGB (Red-Green-Blue) LED
(8) Infrared Receiver	(19) Male/Female Breadboard Jumper Cables
(9) 7-Segment Display	(20) Capacitors (1, 10 and 100µF)
(10) 8 Position SIP DIP Switch	(21) Resistors (100,1K, 10K, 100K and 10M Ohm)
(11) 8 100 Ohm Resistor SIP	(22) Male/Male Breadboard Jumper Cables



# Introduction to Breadboarding - Breadboard Diagram

TI PROFESSIONAL DEVELOPMENT

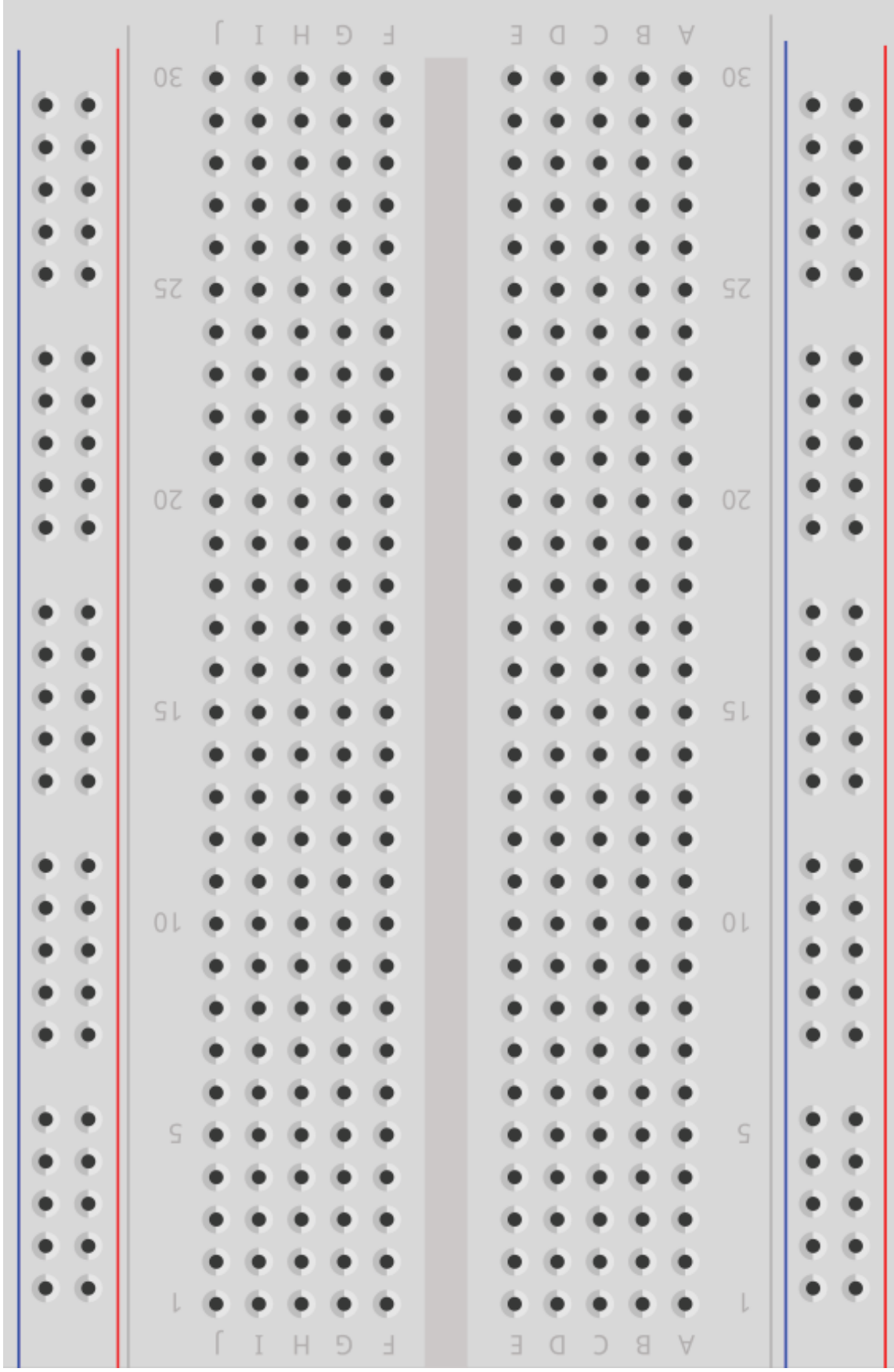



# TI-Innovator™ Breadboard Pack Inventory List







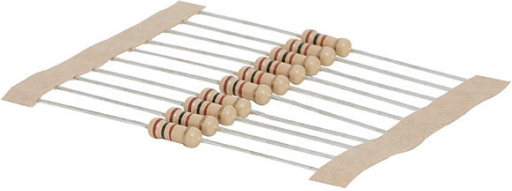

TI PROFESSIONAL DEVELOPMENT

Breadboard	
Male/Female Breadboard Jumper Cables	
Male/Male Breadboard Jumper Cables	
Green LED	
Red LED	
RGB (Red-Green-Blue) LED	
Diode	



# TI-Innovator™ Breadboard Pack Inventory List







TI PROFESSIONAL DEVELOPMENT

Resistors (100, 1K, 10K, 100K and 10M Ohm)	
Thermistor	
SPDT Slide Switch	
8 Position SIP DIP Switch	
8 100 Ohm Resistor SIP	
Potentiometer with Knob	
7-Segment Display	
Capacitors ( 100,10 and 1μF	



# TI-Innovator™ Breadboard Pack Inventory List

TI PROFESSIONAL DEVELOPMENT

Small DC Motor	
TTL Power MOSFET	
TI Analog Temperature Sensor	
Visible Light Sensor	
4-AA Battery Holder	
Infrared Receiver	
Infrared Transmitter	



# Resistors Table

TI PROFESSIONAL DEVELOPMENT

Color	Number	Multiplier
Black	0	1 or ( $10^0$ )
Brown	1	10 or ( $10^1$ )
Red	2	100 or ( $10^2$ )
Orange	3	1000 or ( $10^3$ )
Yellow	4	10000 or ( $10^4$ )
Green	5	100000 or ( $10^5$ )
Blue	6	1000000 ( $10^6$ )
Violet	7	10000000 or ( $10^7$ )
Gray	8	100000000 or ( $10^8$ )
White	9	1000000000 or ( $10^9$ )

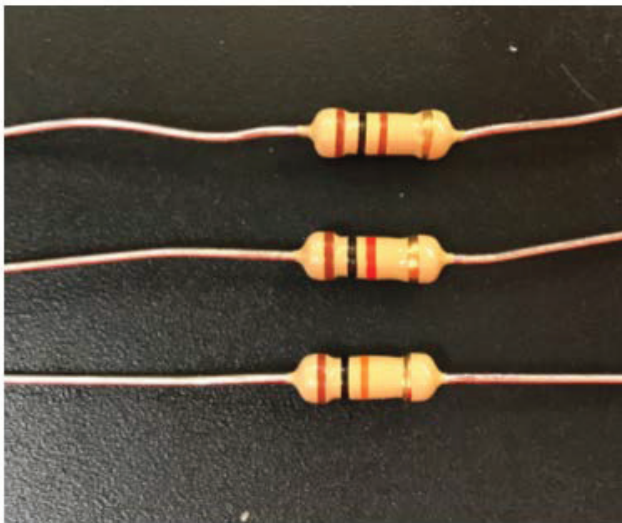

Resistors vary in the amount of resistance to the flow of current. There are four colored bands marked on a resistor. Read from the end that is not gold or silver. The first and second band colors represent the first and second digits in the resistance value. The third colored band represents the factor the first two numbers are multiplied by to equal the resistor value. The fourth band is the manufactured tolerance and is not important in this lesson.

Example: the first resistor is brown (1), black (0), brown (X 10)  $10 \times 10 = 100$

The second one is brown (1), black (0), red (X 100)  $10 \times 100 = 1000$

The third one is brown (1), black (0), orange (X 1000)  $10 \times 1000 = 10,000$

It is a good practice to use a current-limiting resistor in an LED circuit. This resistor prevents too much current from flowing through the device and breaking (burning) the LED. Typically, the current-limiting resistor is placed in series with the cathode (-) lead.



### Skill Builder: Blink

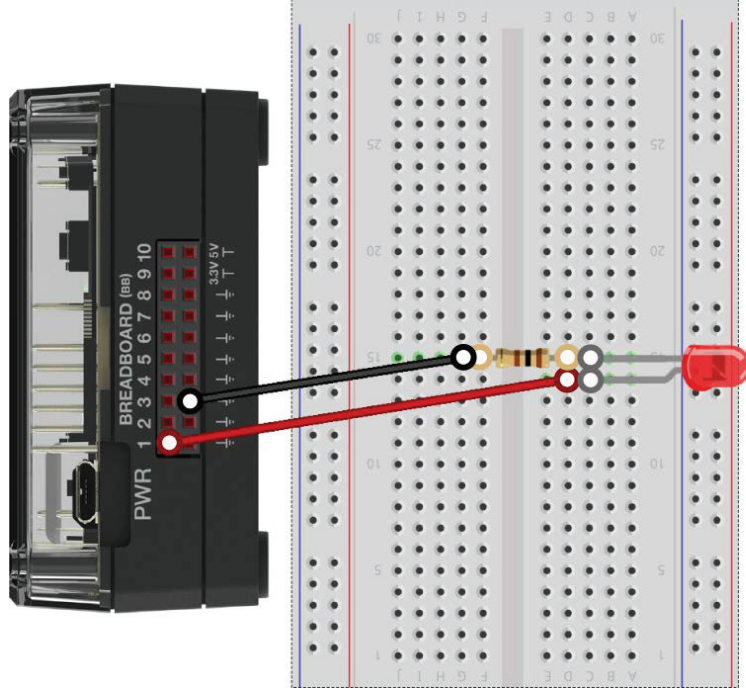

### Project: Build a Speaker

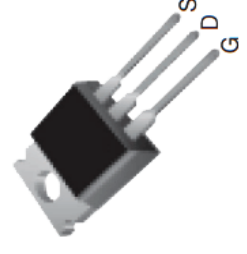
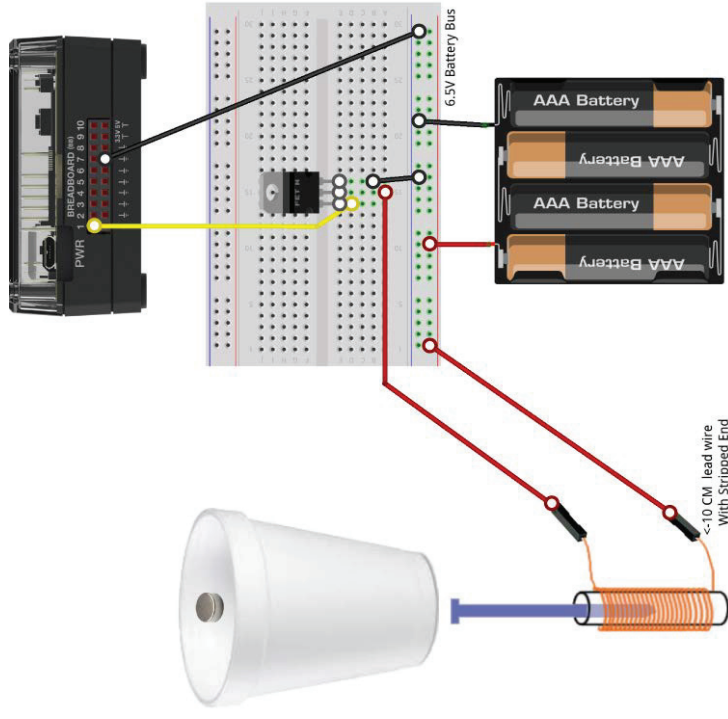

TTL Power MOSFET Diagram  
G- gate, D- drain, S- sink



### Skill Builder: Potentiometer Knob

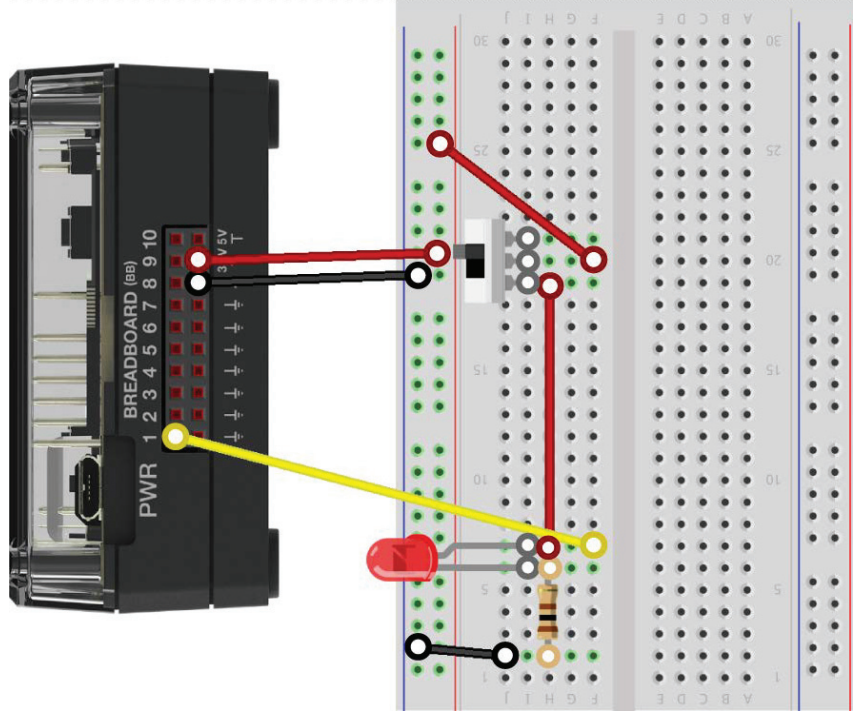

### Project: Banana Switch

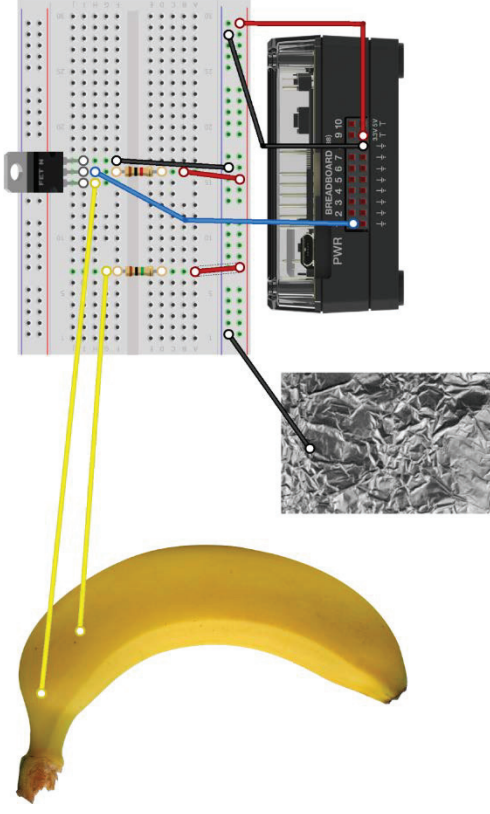

FET Transistor Led Diagram

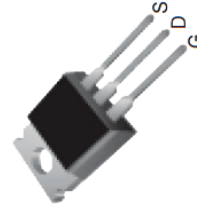

G- gate, D- drain, S- sink





**Skill Builder: Controlling a small DC Motor**

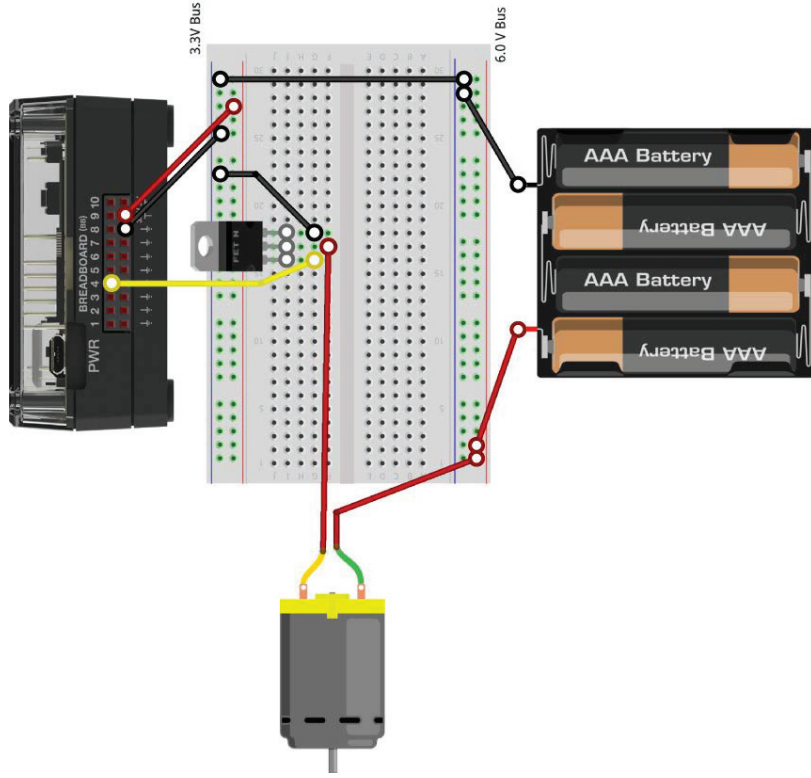

**Project: Mood Lamp Diagram**

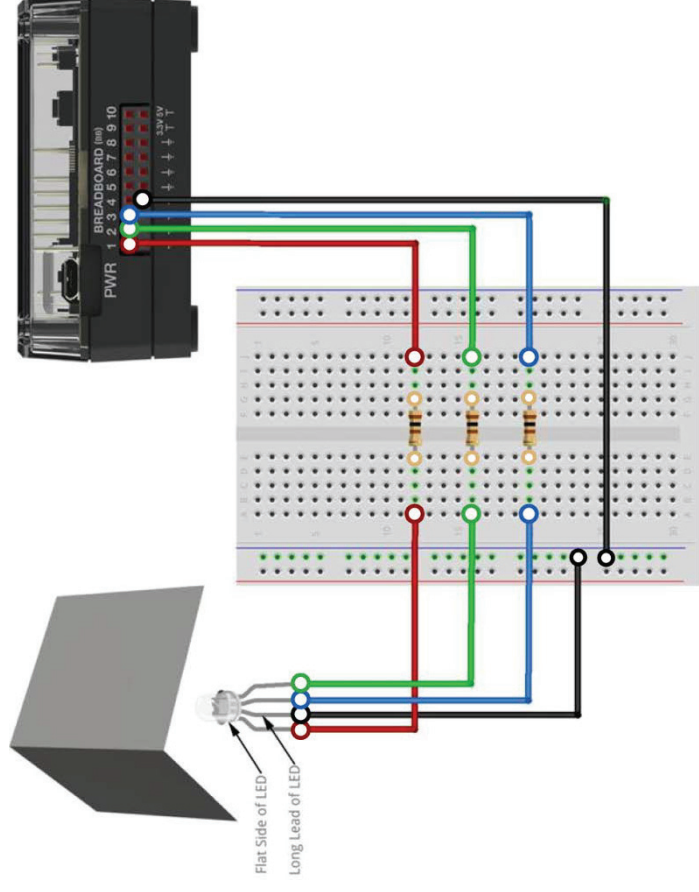



### Skill Builder: Potentiometer with Knob diagram

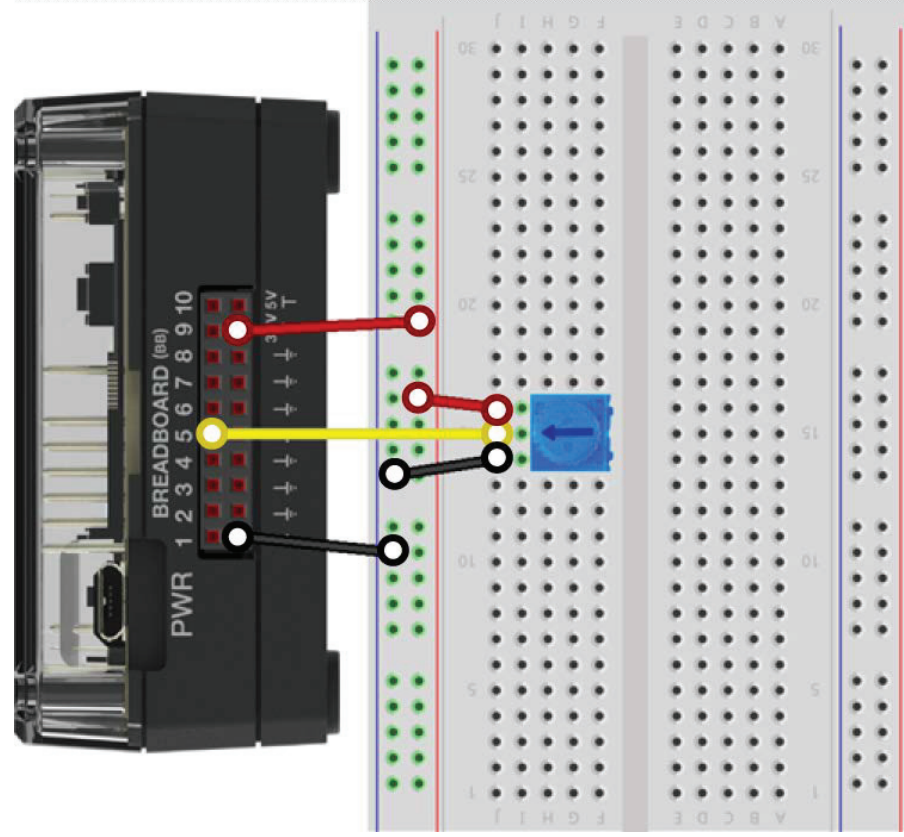

### Project: How Clean is the Water diagram

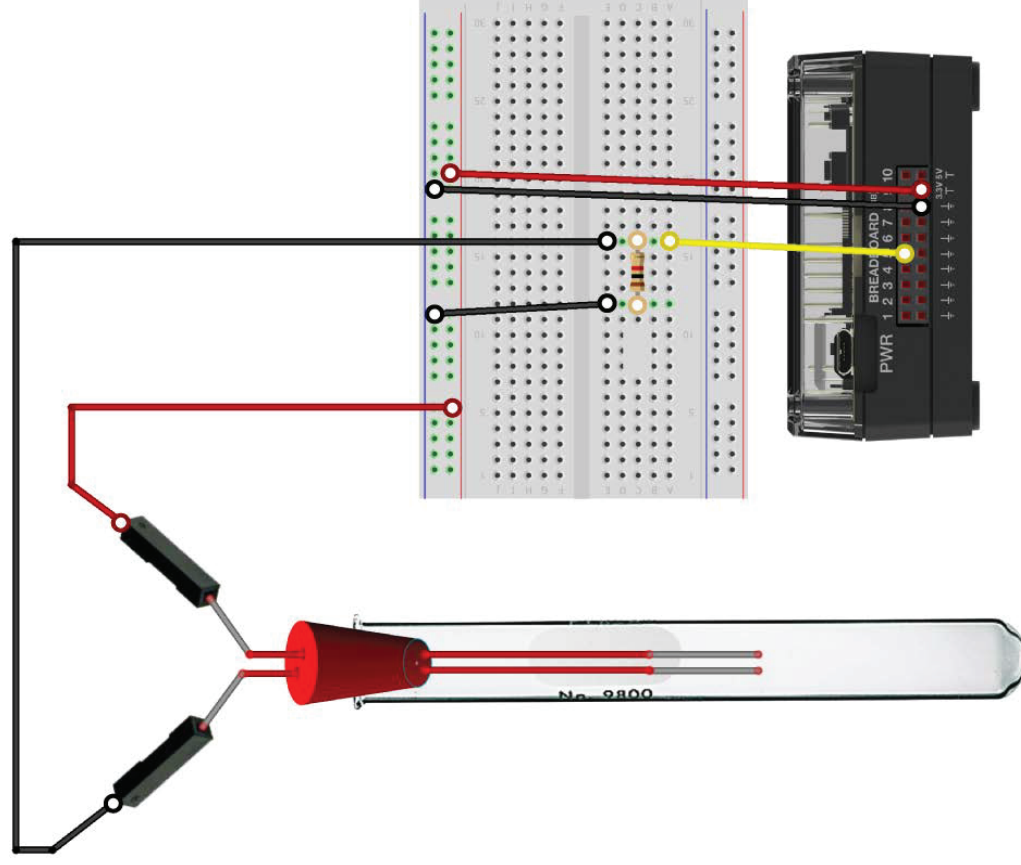



### Skill Builder:

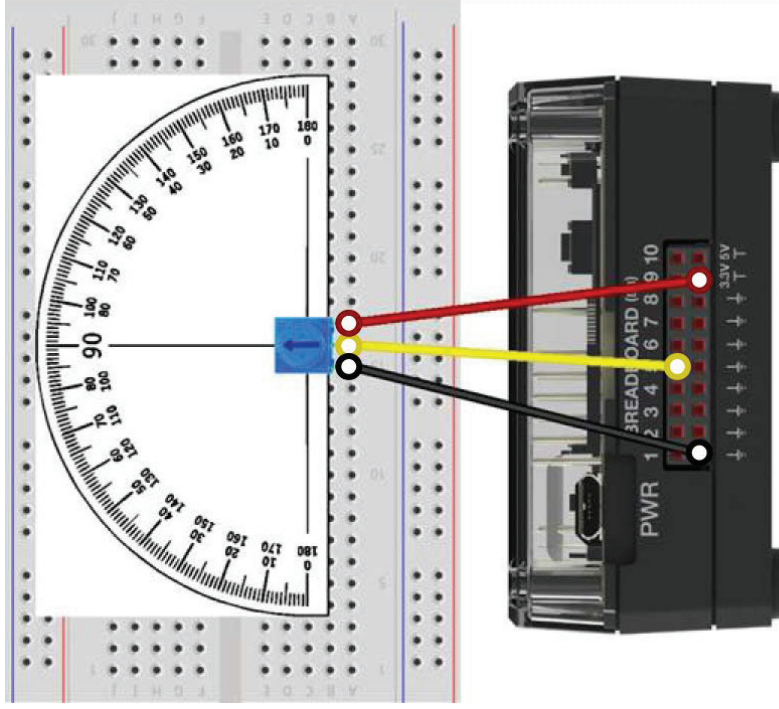

### Project: How to Keep a Lizard Warm

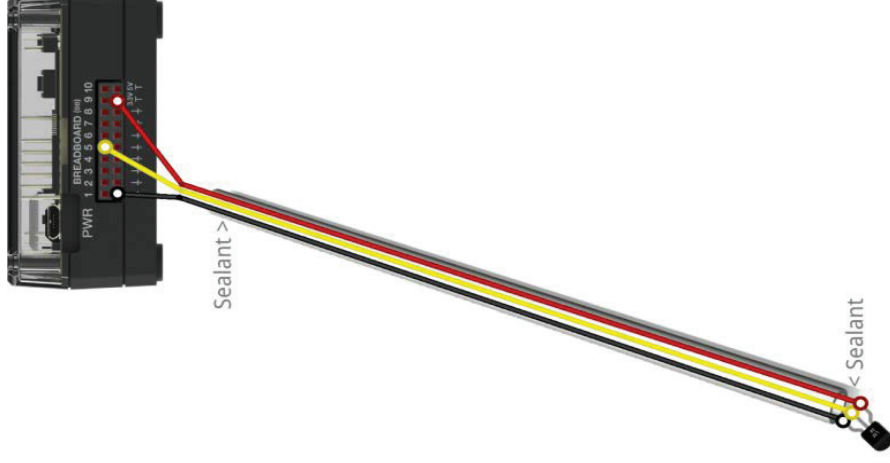

fritzing

### TI Analog Temperature Sensor



## Skill Builder: Night Light

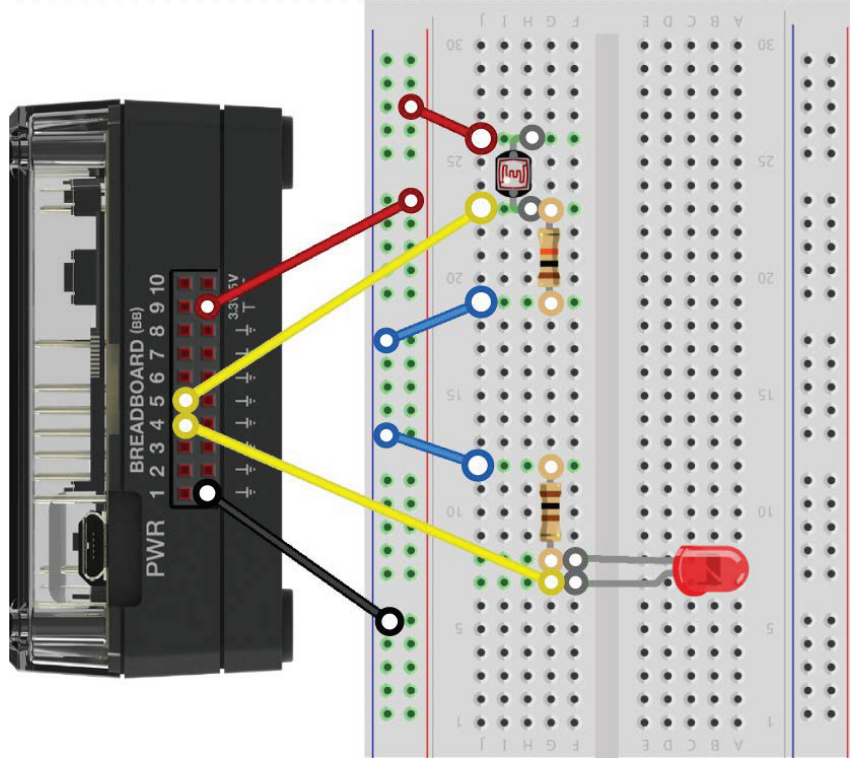

## Project: How to Keep a Lizard Warm

TI Analog Temperature Sensor

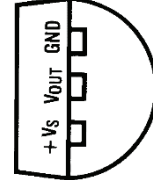
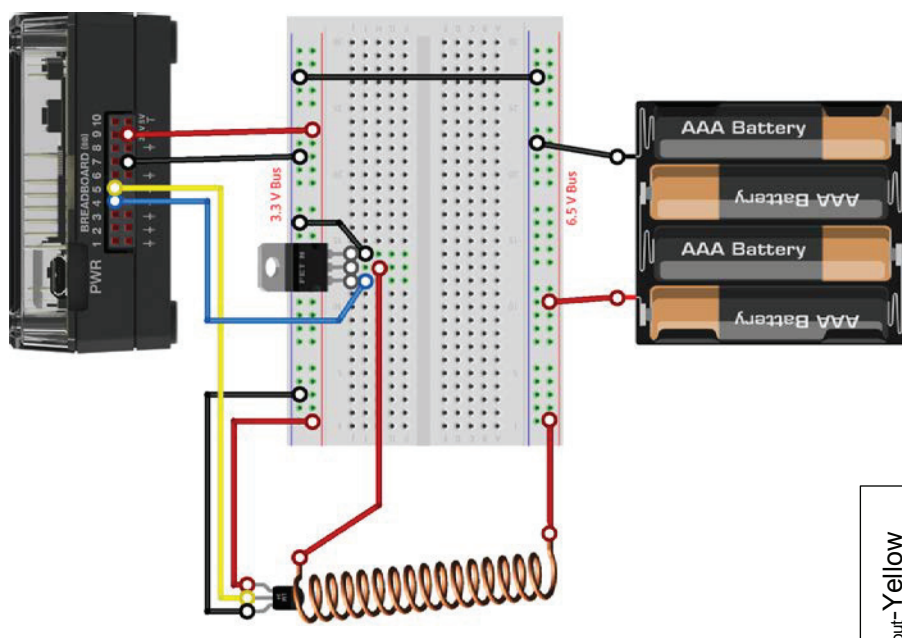

BOTTOM VIEW

V<sub>s</sub>-Red wire, V<sub>out</sub>-Yellow wire, GND-Black wire